

A BROADBAND THz RECEIVER FOR LOW BACKGROUND SPACE APPLICATIONS

C. Hagmann, D. J. Benford, A. C. Clapp, P. L. Richards, and P. Timbriet
Department of Physics, University of California, Berkeley CA 94720

ABSTRACT

We have developed a sensitive bolometric receiver for low background space applications. In a 10 % bandwidth at 1 THz, this receiver is approximately 100 times more sensitive than a quantum limited heterodyne receiver with a 1 GHz IF bandwidth. This receiver is designed to be used for the long wavelength band (200-700 μm) in the MIPS instrument on NASA's SIRTf satellite. The bolometers are cooled to 100 mK by an adiabatic demagnetization refrigerator. Roughly 60 g of cesium chrome alum salt is partially demagnetized to 100 mK, followed by a slow regulated downramp to compensate for the heat leak. The hold time of the ADR system is about 18 hours with a temperature stability of $\Delta T_{\text{rms}} \approx 10 \mu\text{K}$. The composite bolometers have electrical reponsivities of 10^9 V/W and electrical NEP's of about $3 \times 10^{-17} \text{ W}/\sqrt{\text{Hz}}$. The bolometer signals are read out by JFET preamplifiers located on the helium plate and operated at 120 K. We have addressed a number of space qualification issues, such as the development of an analog magnet controller, construction of a cryogenic shake-table for bolometers and selection of the paramagnetic salt CCA which can survive a bakeout at 50 °C. The receiver is scheduled to be flown in the spring of 1992 on a balloon telescope. This flight has a dual purpose. One is to provide a realistic test of the capabilities of the new receiver. The other is to search for anisotropies in the cosmic microwave background on scales of a few degrees.

† Present address: Dept. of Physics, Brown University, Providence RI 02912

INTRODUCTION

Since the highly successful flight of the Infrared Astronomical Satellite (IRAS) in 1982, much work has been devoted towards the development of a new generation of low background receivers. NASA's Space Infrared Telescope Facility (SIRTF) is a LHe cooled long-life instrument, which will allow background or confusion limited observations for wavelengths ranging from 2-700 μm . The long wavelength band covers the spectral range of 200-700 μm , which is 0.4-1.5 THz. Scientific targets for the long wavelength capability of SIRTF include quasars, brown dwarfs, protogalaxies and the cosmic microwave background.

In principle either direct detectors or heterodyne receivers could be used at this wavelength. For broadband photometry, direct detectors are more sensitive than heterodyne receivers due to their wider bandwidth and lack of quantum noise. The baseline instrument for long wavelength photometry on SIRTF is a bolometric receiver operating at 0.1 K and cooled by an adiabatic demagnetization refrigerator (ADR). A prototype of this receiver has been constructed and will be flown on a balloon borne telescope as a realistic test of its flight worthiness.

REFRIGERATOR

The 100 mK refrigerator [1], shown in Figure 1, operates by adiabatically demagnetizing a paramagnetic salt. The ADR cycle starts by thermally shorting the 100 mK stage to the helium bath cold plate at $T \approx 1.5$ K. This is accomplished with a mechanical heat switch actuated by a superconducting solenoid located on the helium plate. In the 'ON' position, a current of 100 mA actuates the solenoid, which forces two jaws to clamp a cold finger

attached to the 100 mK stage. The resulting pressure contact has a thermal conductance of about 10 mW/K at $T=1.5$ K. In the 'OFF' position, a spring pushes the jaws apart.

The field for magnetizing the paramagnetic salt is produced by a conduction cooled superconducting solenoid with a rated central field of 2.5 T for 6 A of current. The magnet is surrounded by a ferromagnetic shield made of vanadium permendur to reduce the stray field to insignificant levels and to increase the field homogeneity within the coil. This shielding material was chosen because of its high saturation flux density and small remanence.

Our ADR uses the hydrated paramagnetic salt cesium chrome alum $\text{CsCr}(\text{SO}_4)_2 \cdot 12 \text{H}_2\text{O}$ (CCA) as its working substance. The magnetic ions Cr^{3+} ($J=3/2$) in this salt have a density of $2.1 \times 10^{21} \text{ cm}^{-3}$ and order at around $T=20$ mK due to their weak magnetic interaction. To make good thermal contact between the salt and the rest of the 100 mK stage, the salt is grown directly on a skeleton of 200 gold wires. The 60 g of salt in the pill is approximately 0.1 mole. The salt is corrosive and has a tendency to dehydrate in air. To prevent any degradation, the salt pill is sealed in a stainless steel can; the gold wires are brought outside through a hardsoldered seal and are hardsoldered to a copper cold stage.

The salt pill is suspended from the surrounding 1.5 K cold plate with two sets of six Kevlar ropes on each end. The suspension can be made very stiff because of the high tensile strength of Kevlar; the fundamental resonant frequency is about 200 Hz. The heat leak through the Kevlar suspension is measured to be $0.25 \mu\text{W}$.

During isothermal magnetization, the magnetic field is ramped up to 2.5 Tesla and then held constant while the cold stage is allowed to equilibrate for about 30 minutes. The chromium spins align in the external field and the entropy is reduced by about 70 %. The heat switch is then opened and the magnetic field is ramped down, cooling the stage adiabatically. When the stage temperature reaches $T=100$ mK, the fast downramp is stopped and a PC based temperature controller [2] maintains $T=100$ mK by slowly reducing the field, thereby compensating for the heat leak through suspension and wiring. The hold time has been measured to be 18 hours with a temperature stability of

$\Delta T_{\text{rms}} \approx 3 \mu\text{K}$. For SIRTf and balloon use, a compact analog PID controller has been developed which has achieved temperature stabilities of about $10 \mu\text{K}$.

After the magnetic field has been reduced to zero, the heat switch is closed and the refrigerator is cycled again. The duty cycle of the refrigerator is more than 95 %.

BOLOMETERS

We are currently testing and optimizing composite bolometers constructed in similar ways to the devices used at and above temperatures of 300 mK [3,4]. A schematic picture of a bolometer [4] is shown in Figure 2. The main elements of the bolometer are a radiation absorber, a thermistor to sense the deposited power and a weak thermal link to the 100 mK plate.

The absorber consists of a $\approx 600 \text{ \AA}$ thick film of Bi evaporated on a $2\text{mm} \times 2\text{mm} \times 35\mu\text{m}$ diamond substrate. The absorptivity of this structure has been measured to be about 50 % for frequencies from $15\text{-}250 \text{ cm}^{-1}$ and normal incidence [5]. The bolometer is enclosed in an optical cavity to maximize the optical efficiency. The substrate is supported by two strands of $\approx 10 \mu\text{m}$ thick Nylon fiber under tension.

For the temperature sensing element we use a neutron transmutation doped chip of germanium ($200\mu\text{m} \times 200\mu\text{m} \times 200\mu\text{m}$) [6]. Ohmic contacts are provided on two faces by boron implantation and metallization with layers of Pd and Au. At helium temperatures, the doped germanium is in the hopping conduction regime with a resistance which varies as

$$R = R_0 \exp \left((A/T)^{0.5} \right). \quad (1)$$

The constants R_0 and A depend on geometry and doping. Electrical connections are made by attaching two $6 \mu\text{m}$ thick graphite fibers to the contact pads with silver epoxy. The thermal conductance of the bolometer is

dominated by the Nylon with $G \approx 4 \times 10^{-11}$ W/K at $T = 100$ mK for 12 strands. The time constant of the bolometer is given by $\tau = C/G$ (C is the bolometer heat capacity) and measured to be about 30 ms. Our measured τ 's turned out to be an order of magnitude larger than is extrapolated from values of C and G measured at 300 mK. Sources of this discrepancy are being investigated.

The bolometer sensitivity is typically expressed as a noise equivalent power which has the contributions

$$\text{NEP}^2 = \text{NEP}_{\text{photon}}^2 + 4kT^2G + 4kT^2R/|S|^2 + e_n^2/|S|^2 \quad (2)$$

where e_n is the voltage noise of the JFET preamp and S is the voltage responsivity given by

$$S(\omega) = I \cdot (dR/dT) \cdot |G + i\omega C|^{-1} \quad (3)$$

and I is the bias current and $\omega/2\pi$ is the chopping frequency.

We have measured electrical NEP's of 3×10^{-17} W/ $\sqrt{\text{Hz}}$ for a chopping frequency of 6 Hz. We are planning to measure the absorbed power NEP by replacing the Bi film absorber with a meander line bismuth heater. Other groups have seen indications of an electric field dependent thermistor resistance and an increasing thermal resistance between phonons and electrons in the NTD germanium at our operating temperatures. Either effect would give an absorbed power NEP which is larger than the electrically measured NEP.

The bolometer voltage is read out by a JFET pair (Interfet NJ132L) packaged in a light-tight can and heated to the optimum temperature of about 120 K. Typical noise voltages are 5-6 nV/ $\sqrt{\text{Hz}}$ at 6 Hz. The JFET current noise is not significant for bolometer resistances of about 10M Ω . We use a Kapton stripline with Constantan conductors for the high impedance leads between the bolometer and the JFETs to avoid microphonic noise, crosstalk, and excessive thermal conductance.

SPACE FLIGHT ISSUES

In order to make our receiver space qualifiable, a number of issues need to be addressed. Since the SIRTf cryostat is likely to be baked during pump out, all ADR components have to survive a simulated bake out test. Commonly used paramagnetic salts such as FAA (ferric ammonium alum) and CPA (chrome potassium alum) dehydrate in sealed containers at temperatures as low as 35 °C. Bake out tests with CCA indicate allowed temperatures of at least 50 °C. The large size of the cesium ion leads to a tighter binding of the waters of hydration in the crystal. An undesirable side effect is the very low solubility of CCA in water, which complicates crystal growth.

Another important topic is survivability of the instrument during launch. We have already carried out a shake test of the suspension system at room temperature and at $T = 77\text{K}$. The tests show a fundamental resonance at 200 Hz with a Q of about 100. Since the flat vibration spectrum of the rocket is amplified at that frequency, it should not coincide with any bolometer resonances. To investigate the bolometer vibration spectrum of the bolometer, we developed a cryogenic shake table based on an electromagnetic vibrator immersed in liquid helium. The force is transmitted into a vacuum can through a bellows. We can subject small mass objects such as bolometers to accelerations of up to 60 g (rms).

We have run a reliability test on the mechanical heat switch by cycling it for 4000 times which corresponds to 8 years in orbit. No degradation in switch performance was detected.

An overall test of the system will be carried out during an upcoming flight of a balloon borne telescope [7,8] for measuring the anisotropy of the cosmic microwave background. In previous flights we used ^3He cooled bolometers with NEP's of about $1 \times 10^{-16} \text{ W}/\sqrt{\text{Hz}}$. The 100 mK bolometers are expected to provide significantly lower noise. The balloon photometer has a multimode broadband feedhorn, and dichroic filters which split the beam into four bands at 3, 6, 9, and 12 cm^{-1} (90, 180, 270, and 360 GHz). In addition, we use quartz and glass bead filters to attenuate high frequency power. The overall

optical efficiency of the balloon photometer from cryostat window to detector is approximately 20 %.

CONCLUSIONS

We have developed a bolometric THz receiver for space applications which operates at 100 mK and achieves an NEP of about 5×10^{-17} W/ $\sqrt{\text{Hz}}$. To compare this with the potential sensitivity of heterodyne receivers, we can calculate the noise equivalent temperature (NET) for both types of receiver. Assuming a 10 % bandwidth at 1 THz, the diffraction limited Rayleigh-Jeans power is $P_s \cong 2kTB$ and $\text{NET} \cong \text{NEP}/2kB \cong 1.8 \times 10^{-5}$ K/ $\sqrt{\text{Hz}}$. For a quantum noise limited heterodyne receiver with an IF frequency of 1 GHz we calculate an $\text{NET} = hv/k\sqrt{B_{\text{IF}}} = 1.5 \times 10^{-3}$ K/ $\sqrt{\text{Hz}}$. This particular example gives a 100 times greater sensitivity for the bolometric receiver.

At present the status of the bolometer channels on SIRTf is uncertain due to budgetary limitations. A great opportunity would be missed and much valuable science lost for the SIRTf mission if the bolometer channels were to be removed.

ACKNOWLEDGEMENTS

This work was supported by NASA grants NSG-7205, FD-NAGW-2121 and JPL contract 958764, and by the Center for Particle Astrophysics through NSF cooperative agreement AST 8809616.

REFERENCES

- [1] P.T. Timbie, G.M. Bernstein, and P.L. Richards, *Cryogenics* **30**, 271, (1990).
- [2] G. Bernstein, S. Labov, D. Landis, N. Madden, I. Millet, E. Silver, and P. Richards, *Cryogenics* **31**, 99, (1991).
- [3] A.E. Lange, E. Kreysa, S.E. McBride, P.L. Richards, and E.E. Haller, *Intl. J. Infraared and Millimeter Waves*, **4**(6), 689, (1983).
- [4] D.C. Alsop, C. Inman, A.E. Lange, and T. Wilbanks (in preparation).
- [5] J. Clarke, G.I. Hoffer, P.L. Richards, and N.H. Yeh, *J. Appl. Phys.*, **48**(12), 4865, (1977).
- [6] E.E. Haller, *Infrared Phys.*, **25**, 257, (1985).
- [7] M.L. Fischer, D.C. Alsop, E.S. Cheng, A.C. Clapp, D.A. Cottingham, J.O. Gunderson, T.C. Koch, E. Kreysa, P.R. Meinhold, A.E. Lange, P.M. Lubin, P.L. Richards, and G.F. Smoot, *Ap.J.* (in press).
- [8] D.C. Alsop, E.S. Cheng, A.C. Clapp, D.A. Cottingham, M.L. Fischer, J.O. Gunderson, E. Kreysa, A.E. Lange, P.M. Lubin, P.R. Meinhold, P.L. Richards, and G.F. Smoot, *Ap.J.* (submitted).

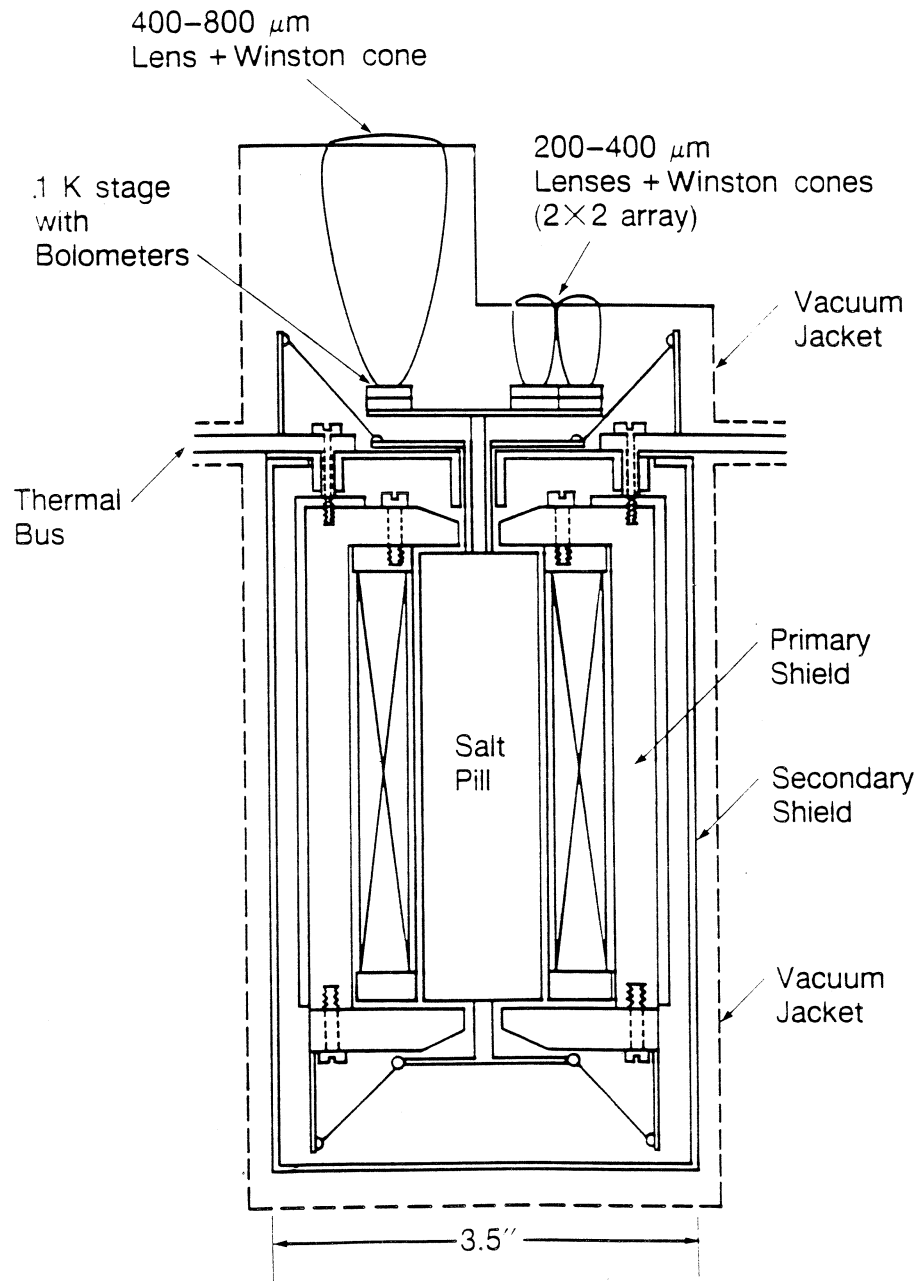

Figure 1: Adiabatic demagnetization refrigerator

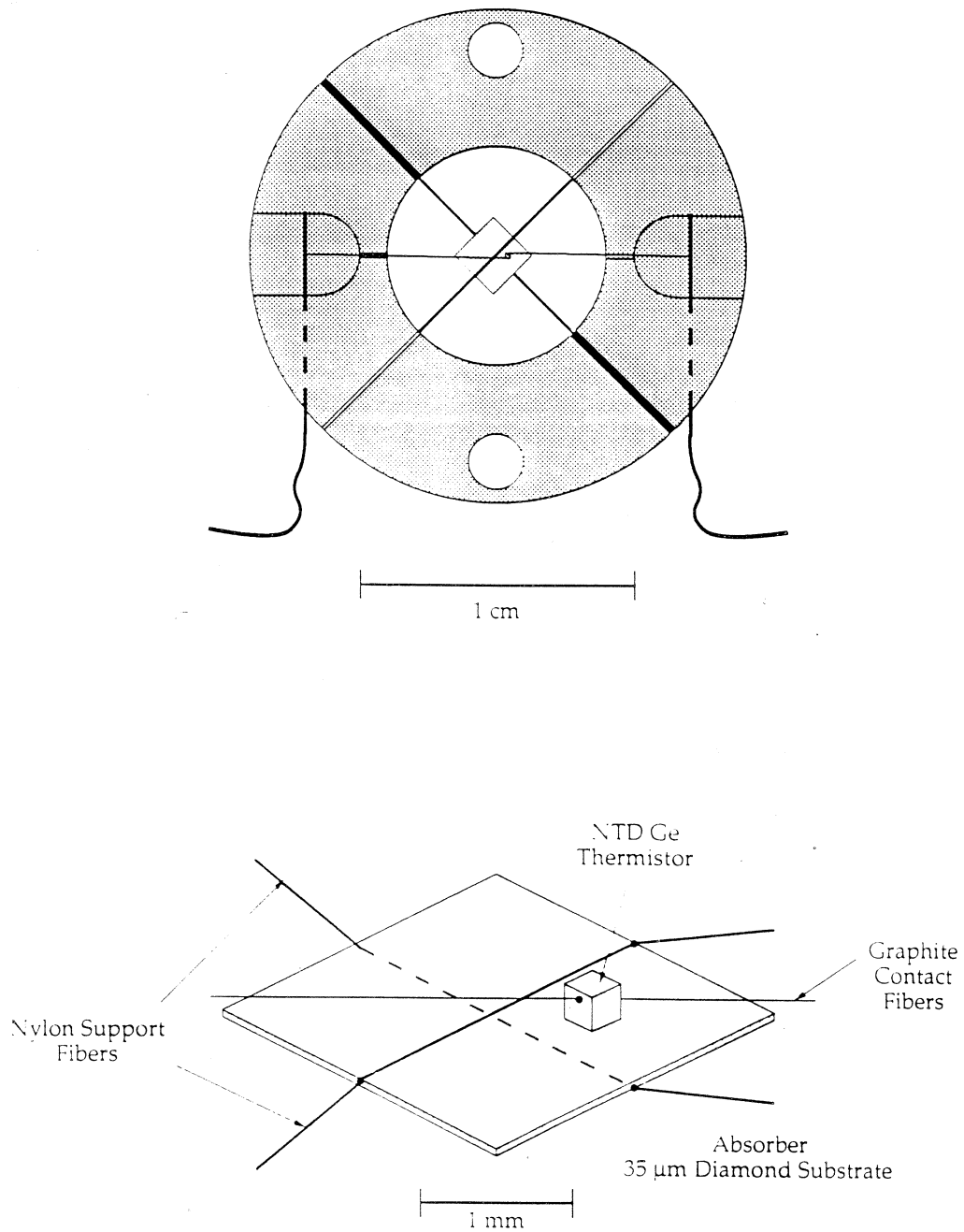

Figure 2: Sketch of a composite bolometer