

ZONE PLATE LENS ANTENNAS FOR MILLIMETER AND SUBMILLIMETER WAVELENGTHS

Paul F. Goldsmith

Five College Radio Astronomy Observatory
Department of Physics and Astronomy
University of Massachusetts, Amherst MA 01003

and

Millitech Corporation
P.O. Box 109
South Deerfield, Massachusetts 01373

Abstract

Zone plate lenses are a type of focusing element which function essentially as differential phase shifters, having a relatively few, coarsely quantized phase delays across the incident beam of radiation. The major advantages are ease of fabrication and much reduced thickness, compared to conventional refractive focusing elements. These considerations are both of particular importance for the submillimeter range, in which manufacturing tolerances for curved optical elements can pose significant problems, and where the absorption of readily available dielectric materials is quite large. In this presentation we briefly review the theory of zone plate lens operation, present a relatively simple method for calculating the aperture efficiency of zone plate lenses used as antennas, and show some theoretical and measured results in the 100 GHz range.

I. Lens Operation as a Phase Transformer

An ideal lens changes the radius of curvature of an incident beam of radiation without affecting its amplitude distribution. This situation is illustrated in Figure 1, which shows a phase transformer converting a diverging spherical wave (as might be produced by a feed horn) into a plane wave. In the paraxial limit, the phase variation of a spherical wave perpendicular to an axis from its focus is a quadratic function of the radius r from the axis:

$$\Delta\varphi(r) = \pi r^2 / \lambda R \quad , \quad (1)$$

where λ is the wavelength and R is the radius of curvature. The phase variation is defined in the sense that the phase delay increases with increasing distance from the axis of propagation.

A lens modifies the radius of curvature of the beam by making use of different propagation speeds in different media; these can be dielectrics for which the speed is less than that in free space by a factor n , and arrays of waveguides or metal plates for which the propagation speed is greater than c according to the general relationship

$$v = c / [1 - (\lambda / \lambda_{co})^2]^{0.5} \quad . \quad (2)$$

Reduced to simplest terms, a dielectric lens modifies the phase distribution by providing a phase delay which decreases away from its axis according to

$$\Delta\varphi_l(r) = - \pi r^2 / \lambda F \quad , \quad (3)$$

where F is the focal length of the lens. The output phase variation is just the sum of that of the input beam given by (1) together with that of the lens given by (3), so that we obtain

$$\pi r^2 / \lambda R_{out} = \pi r^2 / \lambda R_{in} - \pi r^2 / \lambda F \quad , \quad (4a)$$

which leads immediately to the relationship

$$1/R_{out} = 1/R_{in} - 1/F \quad . \quad (4b)$$

With the convention that $R_{\text{in}} = D_{\text{in}}$, the distance of the focal point of the input beam from the lens, and $R_{\text{out}} = -D_{\text{out}}$ (the distance to the focal point of the output beam), we recover the familiar expression

$$1/D_{\text{in}} + 1/D_{\text{out}} = 1/F \quad . \quad (4c)$$

Equation (4b) also applies to quasioptical Gaussian beams [1], while (4c), being dependent on the assumption that the radius of curvature is equal to the distance from the focal point, applies only to geometrical optics beams.

A converging dielectric lens of index of refraction n has a central thickness t_c determined by the maximum phase delay that is required:

$$\Delta\varphi_{\text{max}} = (2\pi/\lambda) \cdot t_c \cdot (n - 1) \quad . \quad (5)$$

In the simplest approximation, we find that the central thickness of a lens of diameter D and focal length F is

$$t_c = D^2/8(n - 1)F \quad . \quad (6)$$

II. LENS LOSS

A lens which operates perfectly as a phase transformer may still suffer loss as a result of reflections at free space – dielectric interfaces, and absorption within the lens itself. Reflection losses are typically a few percent per surface if no anti-reflection treatment is employed. The basic technique to reduce reflections is to include a matching layer, which may be a natural dielectric of the required index of refraction, or an artificial dielectric as formed by cutting grooves. Both approaches have limitations due to variations in incidence angle and polarization effects, but can reduce reflections significantly.

Absorption cannot be eliminated, and depends on the lens thickness, together with the material properties. We use the definition of the fractional power loss per unit distance to be α , so that the input and output power (or power density) after traversing a path through the dielectric of length L are related by

$$P_{\text{out}} = P_{\text{in}} \cdot \exp(-\alpha L) , \quad (7a)$$

where

$$\alpha = 2\pi n \tan \delta / \lambda . \quad (7b)$$

In the preceding equations, we have employed the usual definitions of the complex dielectric constant $\epsilon = \epsilon' + i\epsilon''$, the index of refraction $n = \sqrt{\epsilon'}$, and the loss tangent, $\tan \delta = \epsilon'' / \epsilon'$.

At submillimeter wavelengths, information on dielectric properties is quite scarce and often not entirely consistent. Some of this may be a result of variations in sample properties, while measurement techniques and errors may also be playing a role. Teflon is a low-loss dielectric widely used for millimeter and submillimeter wavelength lenses. This material has an absorption coefficient which rises almost linearly with frequency, and is approximately 0.042 cm^{-1} at 300 GHz and 0.09 cm^{-1} at 600 GHz [2]. Other measurements give higher absorptions of $0.2 - 0.5 \text{ cm}^{-1}$ at ≈ 900 GHz [3]. We adopt an absorption coefficient of 0.1 cm^{-1} at 600 GHz and a real part of the dielectric constant of 2.0. Rexolitetm is often used at millimeter wavelengths due in part to its good mechanical properties. It is relatively lossy in the submillimeter range; different measurements give $\alpha = 0.70 - 1.0 \text{ cm}^{-1}$ at 600 GHz [4].

Taking (6) as giving a representative lens thickness, we find $t_c = 0.31 D^2/F$. For a $F = D = 5 \text{ cm}$ lens at 600 GHz, we find $t_c = 1.55 \text{ cm}$; a perfectly phase correcting plano-convex lens of the same focal length and diameter has $t_c = 1.475 \text{ cm}$. The absorptive loss at the center of a $F = D = 5 \text{ cm}$ teflon lens (where most of the power is concentrated) will thus be about 15 %. A comparable rexolitetm lens will have an absorption at its center of approximately 60 %! Clearly, these numbers are large enough to suggest the use of refractive optics. An alternative that merits serious consideration is the zone plate lens, which can be made far thinner and thus have negligible absorption loss.

III. Zone Plate Lens Operation

The monotonically decreasing phase delay as a function of distance from the axis of

symmetry characteristic of typical dielectric lenses (Figure 2a) can be interrupted by a step change in thickness. If at a particular frequency this produces an increase in the phase delay equal to 2π radians, it will nominally not have any effect on lens performance, except for possible shadowing by step boundaries. Such devices are generally called **zoned lenses**, or **Fresnel lenses** and are widely used to reduce the thickness of relatively large and thick lenses employed at microwave frequencies. As shown in Figure 2b, they still have at least one surface which has curved sections, so that manufacturing is, in fact, more difficult than conventional lenses since the steps are an added complication.

Zone plate lenses represent a more radical approach, in that, as illustrated in Figure 2c, they are designed using only surfaces perpendicular to the axis of propagation. This is not at all a new concept, deriving quite directly from concept of Fresnel zones in diffraction theory. A number of references which discuss theoretical and experimental aspects of zone plate lenses are given in [5]. The closely related zone plate reflector antenna is discussed in references [6].

Rather than attempting to achieve the desired phase error function (3), the zone plate lens allows the phase error to increase as a quadratic function of distance from the axis. When it has reached a certain point, the lens thickness is reduced to bring the phase error to zero. If we define the maximum allowed phase error to be $2\pi/p$, the axial size of the step is given by

$$t_1 = \lambda/(n-1)p \quad . \quad (8)$$

If this procedure were continued indefinitely, we would merely have a stepped approximation to a conventional lens, which would not be particularly thin. The zone plate lens is distinguished by the technique of **increasing** the phase delay by 2π radians at the design frequency, at points where the previously described procedure of reducing the phase delay would lead to an accumulated phase error of 2π radians. The maximum change in thickness of the zone plate lens is

$$\Delta t_{\max} = [(p-1)/p] \cdot (\lambda/(n-1)) \quad , \quad (9)$$

since at the next step the thickness returns to its original value rather than to $p \cdot t_1 = \lambda/(n-1)$. The total zone plate lens thickness is given by $\Delta t_{\max} + t_{\min}$, where the latter is the minimum thickness required for mechanical integrity. The total thickness is

thus on the order of a wavelength, far less than required for unzoned lenses. The absorption loss for a material with α proportional to frequency will thus be a constant, providing one of the most important advantages of zone plate lenses at submillimeter wavelengths.

The radii at which the zones occur are obtained by requiring that the total phase for rays representing a plane wave converged to focal point be constant for all initial radii from the axis of symmetry. We ignore any phase shift of constant thickness component of lens, and take the phase shift of the zone plate lens to be

$$\Delta\varphi_{zpl} = -2\pi k/p \quad , \quad (10)$$

where k is an index which increases by unity at each zone boundary. As illustrated in Figure 3, the radius of zone k is denoted r_k and the distance from the lens at this radius to the focal point R_k , so that the path phase difference between axial ray and an arbitrary ray is

$$\Delta\varphi = (2\pi/\lambda)[R_k - F] \quad . \quad (11)$$

The two previous equations can be combined with the constant total phase condition to determine R_k . With the additional approximation of ignoring effect of changes in the lens thickness on R_k , we obtain $R_k = [r_k^2 + F^2]^{0.5}$, which gives the relation

$$r_k = [2kF\lambda/p + (k\lambda/p)^2]^{0.5} \quad . \quad (12)$$

Some designs for zone plate lenses are shown in Figure 4, with $p = 2, 4, 10,$ and 50 . All are designed for 300 GHz and have $F = D = 10$ cm, with an index of refraction equal to 1.4. A minimum thickness of 0.1 cm has been arbitrarily chosen. In practice, it is effective to chose the minimum thickness to make the zone plate lens central thickness resonant at the design frequency.

If we restrict ourselves to the situation $F/D \gg 0.5$, the first term in (12) dominates, and we obtain the nominal lens diameter

$$D_0 = [8k_{\max}f\lambda/p]^{0.5} \quad . \quad (13a)$$

Alternatively, we see that the number of zones in the lens is given by

$$k_{\max} = pD_o^2/8f\lambda \quad . \quad (13b)$$

Although zone plate lens design concentrates on phase delays and ignores refraction, an important limitation must be borne in mind, which is that the zone width must be large enough that zones do not begin to act like waveguides, in the manner of matching layers on a conventional dielectric lens. For this reason it is useful to determine the minimum zone width, which is just the minimum value of $\Delta r = r_{k+1} - r_k$. This occurs at the outer radius of the lens where we find

$$\Delta r_{\min} = (2/p) \cdot (f/D) \cdot \lambda \quad . \quad (14)$$

For a $F/D = 1$ zone plate lens with $p = 4$ we find $\Delta r_{\min} = \lambda/2$, which is on the borderline of being a problem; it is apparent that the performance of the outer portion of fast zone plate lenses may be compromised by this effect. Detailed calculations remain to be carried out.

IV. Zone Plate Lens Efficiency

The major issue we wish to investigate is how the wave front errors which are a necessary consequence of the approximate nature of the zone plate lens design affect its efficiency as an antenna. We consider a lens being used to transform a spherical wave into a plane wave and start with a wave of radius of curvature R_{in} ; the phase distribution as a function of distance from the axis is shown in Figure 5a; in the paraxial limit this is just that described by (1). To this we add the differential phase shift produced by the lens which has thickness t at radius r

$$\Delta \varphi_{zpl} = (2\pi/\lambda) \cdot (n - 1)t(r) \quad . \quad (15)$$

The lens shown in cross section in Figure 5b has $p = 4$ and $F/D = 1$. The resulting output or aperture phase distribution is shown in Figure 5c; note that the phase delay increases essentially quadratically as a function of radius, except at the zone boundaries. The $p = 4$ lens has 3 successive zone boundaries at which the phase delay decreases by $2\pi/4$ radians, followed by a boundary at which the phase delay increases by 2π .

In order to calculate the aperture efficiency, we assume that we have a Gaussian feed distribution which yields an aperture field distribution with magnitude of the form

$$|E_{ap}(r)| = \exp [-(r/w)^2] , \quad (16a)$$

which defines the power edge taper

$$T_e(\text{dB}) = 8.69 (R/w)^2 = 2.17 (D/w)^2 . \quad (16b)$$

The taper efficiency is the efficiency with which the aperture is utilized, and is defined by

$$\epsilon_t = \left| \iint E_{ap} \cdot dS \right|^2 / \iint |E_{ap}|^2 \cdot dS \cdot \iint dS , \quad (17a)$$

where all integrals extend over the aperture [7]. The spillover efficiency is the fraction of power in the feed pattern which is intercepted by the aperture, and is given by

$$\epsilon_s = \frac{\iint_{\text{aperture}} |E_{ap}|^2 \cdot dS}{\iint_{\text{entire pattern}} |E_{ap}|^2 \cdot dS} . \quad (17b)$$

The aperture efficiency is the product of the two preceding contributions:

$$\epsilon_a = \epsilon_t \cdot \epsilon_s . \quad (17c)$$

The integral in the numerator of (17a) includes the effects of the phase errors; any deviation from a uniform phase distribution reduces the taper efficiency and thus the aperture efficiency.

The efficiencies can be calculated for different input beam characteristics for a given lens. An edge taper of approximately 10 dB yields the maximum efficiency for this type of illumination of an unblocked antenna [7]. The variation of taper efficiency as a function of input beam radius of curvature is shown in Figure 6a for a zone plate lens with $p = 4$ and $F = D = 10$ cm operating at a wavelength of 0.3 cm. As expected, the maximum efficiency occurs for $R_{in} = F$.

The behavior of the lens efficiency as a function of p is shown in Figure 6b, for the same lens conditions as above, fixing $R_{in} = F$. The values of the efficiencies for large p are

very close to those for a perfect phase transformer with the same 10 dB edge taper: $\epsilon_t = 0.9$, $\epsilon_s = 0.9$, and $\epsilon_a = 0.81$. The efficiencies for $p = 2$ and 3 are quite low, but for $p = 4$ we begin to approach the asymptotic behavior. Thus, the choice of p represents a compromise between obtaining the highest efficiency and ease of fabrication together with the requirement on minimum zone width given by (14).

V. Zone Plate Lens Measurements

We have fabricated and measured a zone plate lens designed for operation at 95 GHz, where test equipment is readily available. The lens was fabricated of Rexolitetm ($n = 1.59$), with $p = 4$, $f = 12.7$ cm, $D = 9.53$ cm, and a central thickness of 0.59 cm. For comparison, we used a fused silica lens which was anti-reflection coated with layers of polyethylene. This lens had the same diameter, but a slightly different focal length of 14.5 cm. Both lenses were illuminated by a scalar feed horn giving a Gaussian illumination pattern with an edge taper of close to 10 dB. The measured patterns in one plane are shown in Figure 7. We see that the main lobe beamwidths are very similar. The sidelobe structure of the unzoned lens is essentially that predicted from the truncated Gaussian illumination. The zone plate lens shows more extended error pattern which is a consequence of the phase errors.

The gains of the two lens antennas were also measured using a compact range; their absolute values are compromised by uncertainty in the gain of the reference horn but are consistent with expectations. What is more reliable is the difference in gain between the unzoned lens and the zone plate lens, which indicate that the zone plate lens has 1.0 dB lower gain. The calculations for the $p = 4$ zone plate lens predict an efficiency 0.86 dB below that of an ideal phase transformer lens. The reflection loss of the $n = 1.6$ zone plate lens is 0.23 dB per surface at normal incidence. Given the possible imperfections in matching, phase transforming, and the absorption in the unzoned lens, the measurements and calculations are in satisfactory agreement.

VI. Conclusions

We have reviewed the theory of operation and design of zone plate lenses. Their very small thickness makes these devices attractive for use at submillimeter wavelengths where absorption loss of unzoned lenses can be appreciable. We have examined the

efficiency of zone plate lenses as a function of interzone phase shift, and find that for zone boundary phase shifts $< \pi/2$ the performance approaches that of an ideal phase transformer. Measurements and calculations of the efficiency of a 95 GHz lens agree quite well.

We thank John Kapitzky, Chris Koh and Ellen Moore for their contributions to this project.

References

- [1] T.S. Chu, "Geometrical Representation of Gaussian Beam Propagation," *Bell Syst. Tech. J.*, 45, pp. 287–299, 1966.
- [2] M.N. Afsar, "Millimeter Wave Complex Refractive Index, Complex Dielectric Permittivity and Loss Tangent Measurements of Common Polar and Non-Polar Polymers," *Proc. Tenth International Conference on Infrared and Millimeter Waves*, pp. 60–61, 1985.
- [3] A.P. Sheppard, A. McSweeney, and K.H. Breeden, "Submillimeter Wave Material Properties and Techniques: Dielectric Constant, Loss Tangent, and Transmission Coefficients of Some Common Materials to 2000 GHz", *Proc. Symposium Submillimeter Waves*, Vol. XX in Microwave Research Institute Symposia Series. Brooklyn: New York Polytechnic Institute Press, 1970, pp. 701–705. G.W. Chantry, *Submillimetre Spectroscopy*. New York: Academic, 1971, p. 341.
- [4] G.J. Simonis, J.P. Sattler, T.L. Worchesky, and R.P. Leavitt, "Characterization of Near-Millimeter Wave Materials by Means of Non-Dispersive Fourier Transform Spectroscopy," *Int. J. Infrared and Millimeter Waves*, 5, pp. 57–72, 1984. R.H. Giles, A.J. Gatesman, and J. Waldman, "A Study of the Far-Infrared Optical Properties of Rexolitetm," *Int. J. Infrared and Millimeter Waves*, 11, pp. 1299–1302, 1990.
- [5] M. Sussman, "Elementary Diffraction Theory of Zone Plates," *Amer. J. Phys.*, 28, pp. 394–398, 1960. F. Sobel, F.L. Wentworth, and J.C. Wiltse, "Quasi-Optical Surface Waveguide and Other Components for the 100- to 300 Gc Region," *IEEE Trans. Microwave Theory Tech.*, MTT-9, pp. 512–518, 1961. D. N. Black and J.C.

- Wiltse, "Millimeter-Wave Characteristics of Phase-Correcting Fresnel Zone Plates," *IEEE Trans. Microwave Theory Tech.*, MTT-35, pp. 1123-1129, 1987.
- J.E. Garrett and J.C. Wiltse, "Fresnel Zone Plate Antennas at Millimeter Wavelengths," *Int. J. Infrared and Millimeter Waves*, 12, pp. 195-220, 1991. This includes a particularly complete of references on this topic.
- [6] L.F. Van Buskirk and C.E. Hendrix, "The Zone Plate as a Radio-Frequency Focusing Element," *IRE Trans. Antennas Propag.*, AP-9, pp. 319-320, 1961. Yu. N. Danilov and L.A. Fedorova, "Scattering Behavior in a Zoned Reflector Antenna," *Izvestiya VUZ. Radioelektronika*, 32(2), pp. 61-65, 1989. R. Lambley, "Fresnel Antenna," *Electronics & Wireless World*, 95, p. 1642, 1989. J.M. Franke and B.D. Leighty, "Reflection Zone Plate Antenna," *NASA Tech. Brief LAR-13535*, 1989. M.A. Gouker and G.S. Smith, "A Millimeter-Wave Integrated Circuit Antenna Based on the Fresnel Zone Plate," *1991 IEEE MTT-S Digest*, pp. 157-160.
- [7] P.F. Goldsmith, "Radiation Patterns of Circular Aperture with Gaussian Illumination," *Int. J. Infrared and Millimeter Waves*, 8, pp. 771-781, 1987.

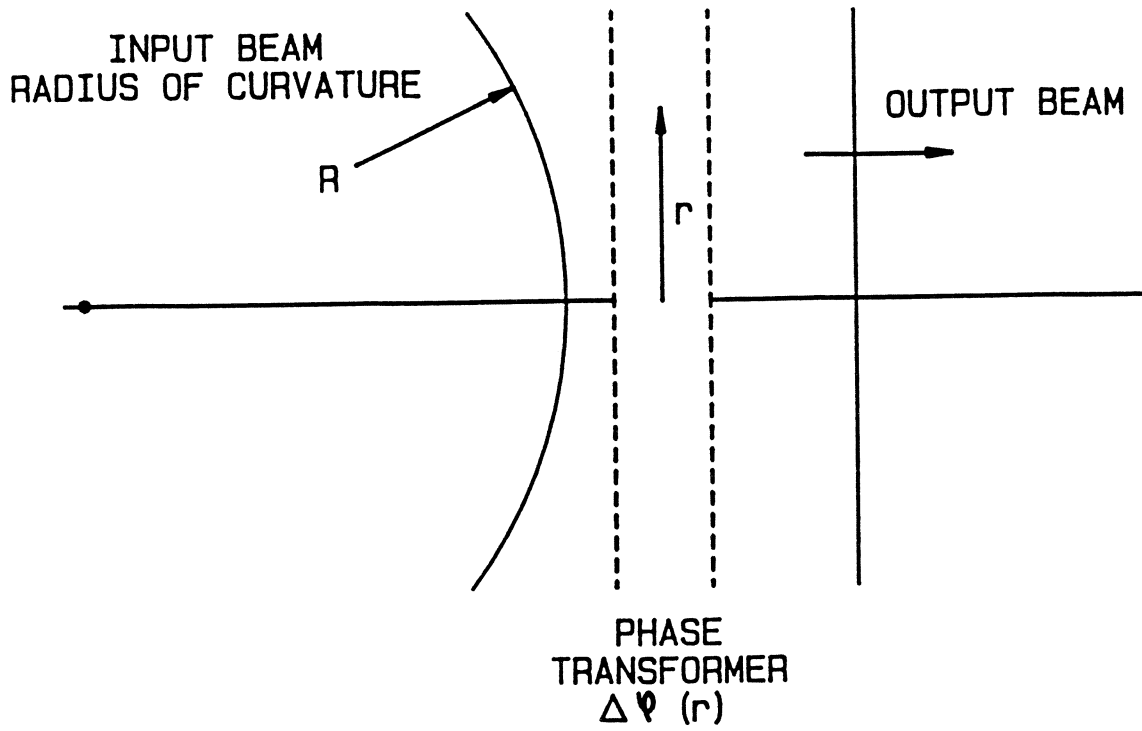

FIGURE 1 - OPERATION OF LENS AS PHASE TRANSFORMER

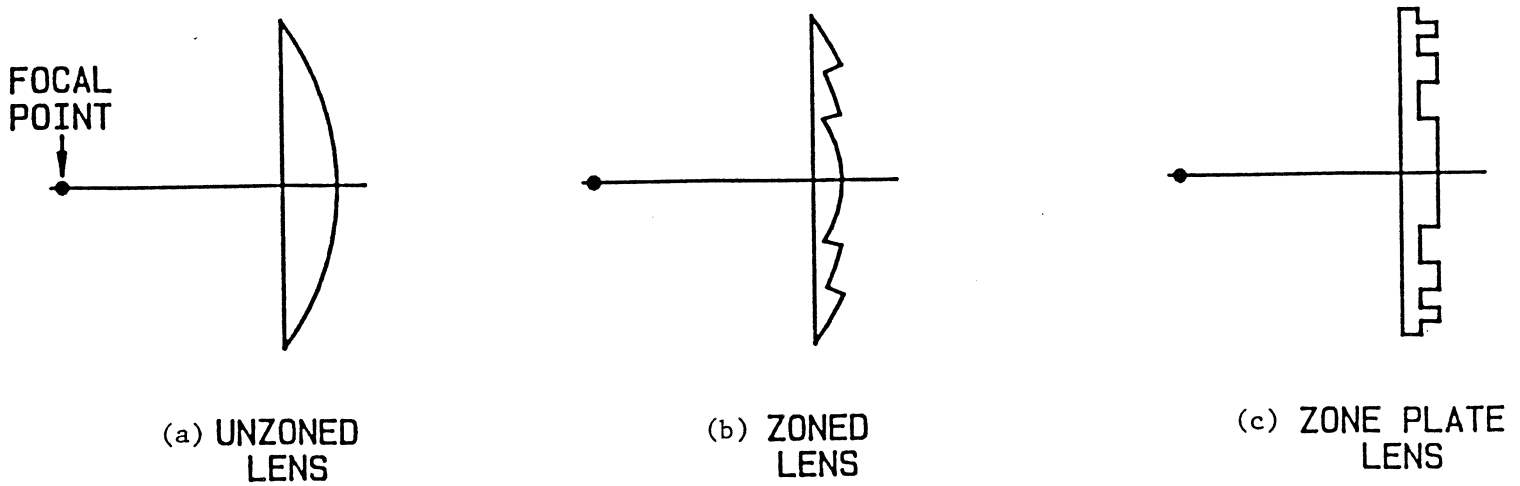

FIGURE 2 - DIFFERENT DESIGNS OF LENSES

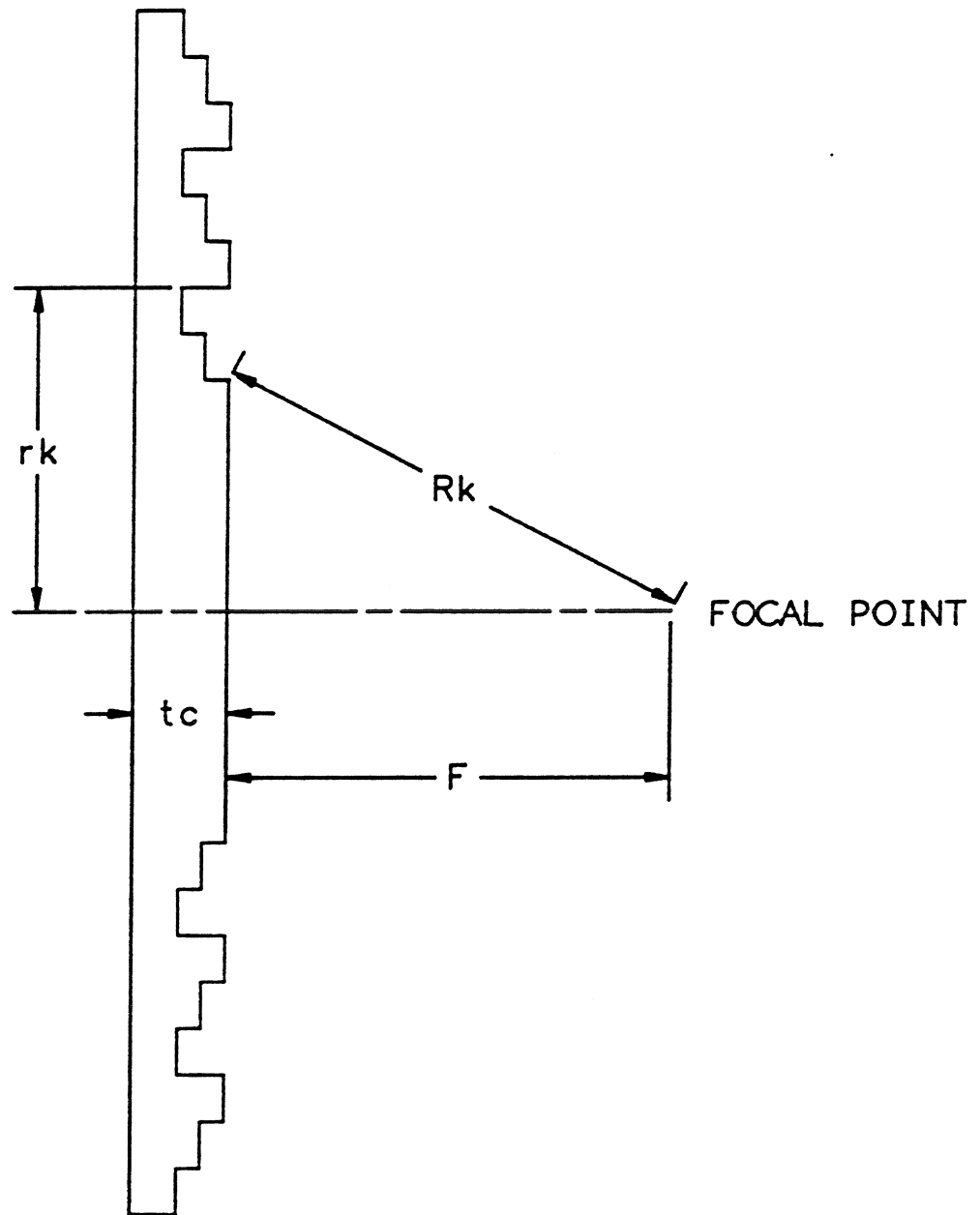
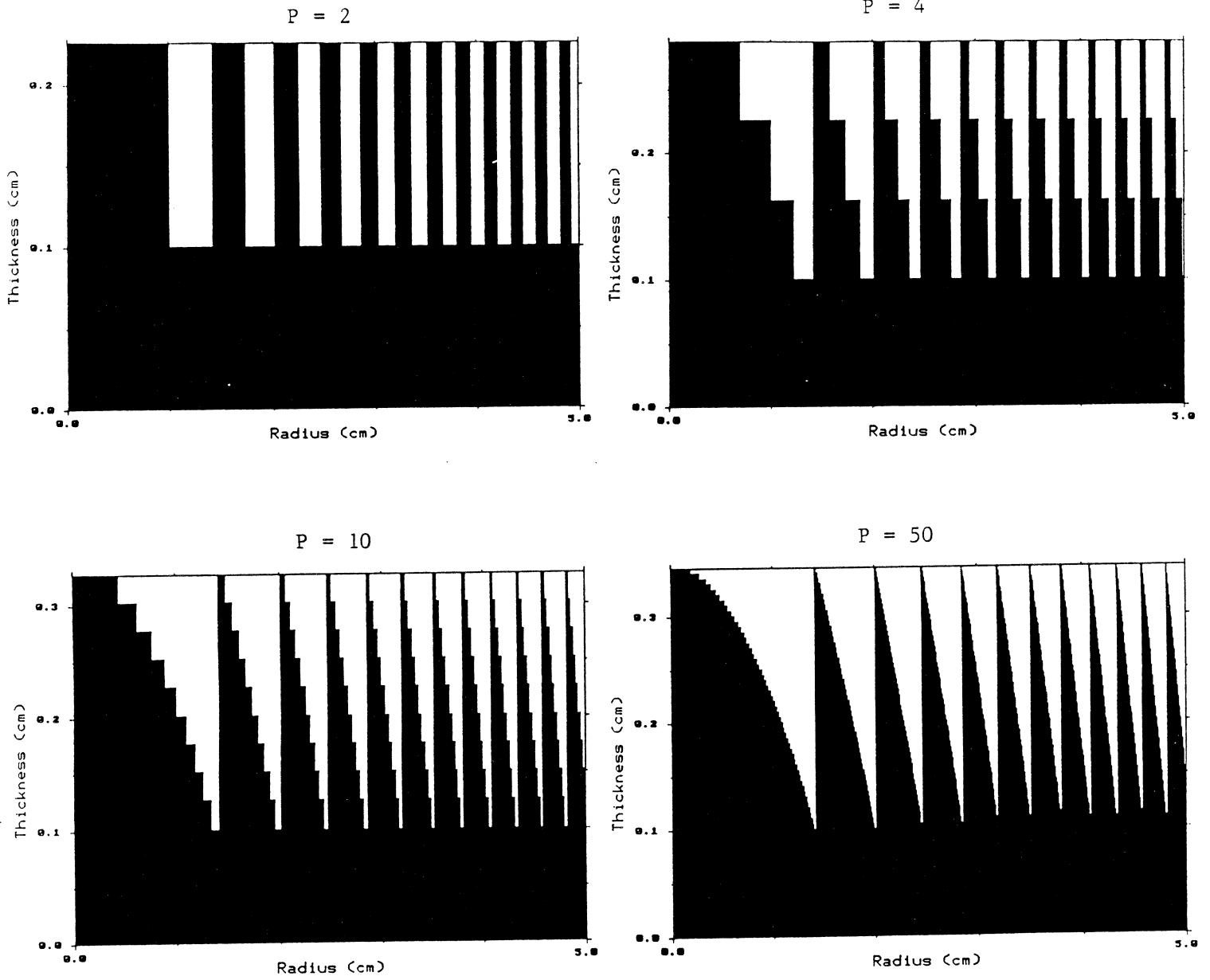

FIGURE 3 - ZONE PLATE LENS DESIGN PARAMETER DEFINITIONS



ZONE PLATE LENSES WITH $F = D = 10$ CM ; FREQUENCY = 300 GHz ; $n = 1.4$

FIGURE 4

FIGURE 5
100 GHZ ZONE PLATE LENS
FL = 10 cm DIA = 10 cm
n = 1.59 p = 4

INPUT PHASE DISTRIBUTION

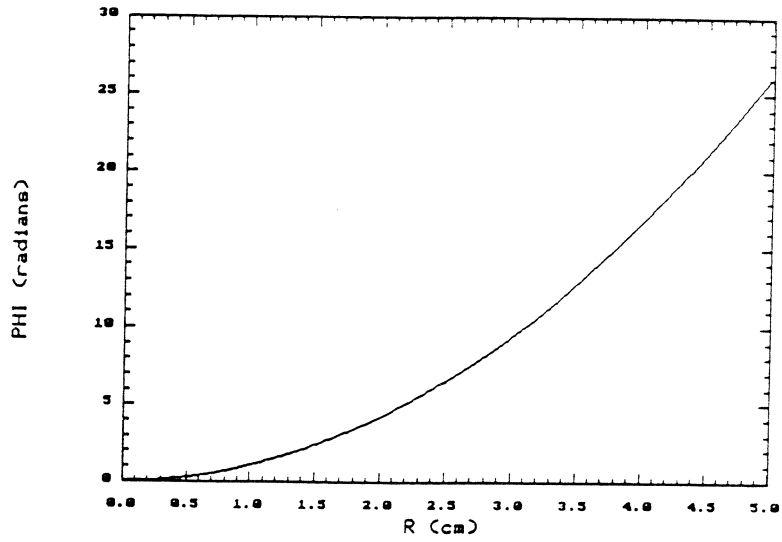

LENS CROSS SECTION

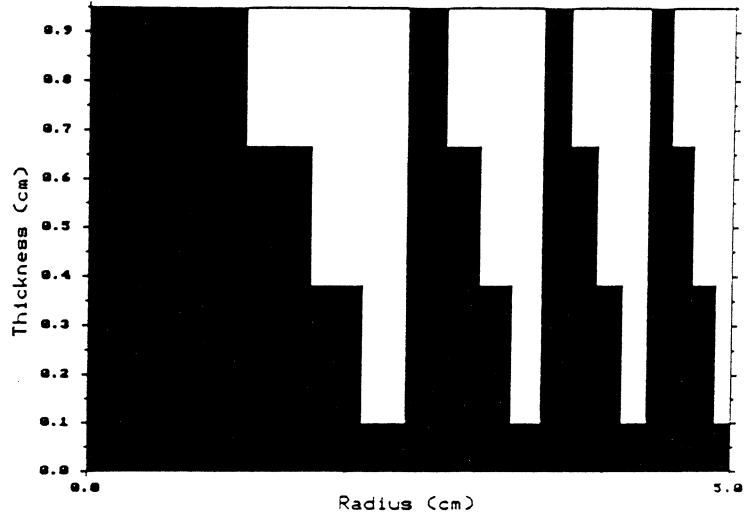

OUTPUT PHASE DISTRIBUTION

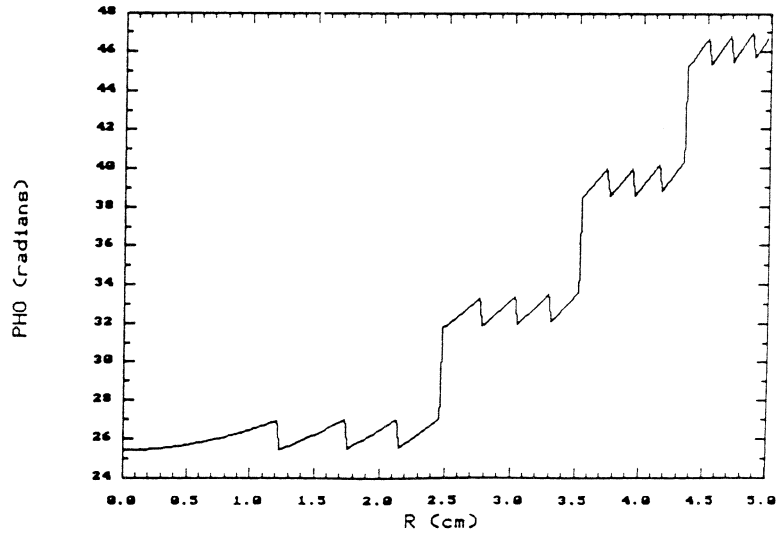

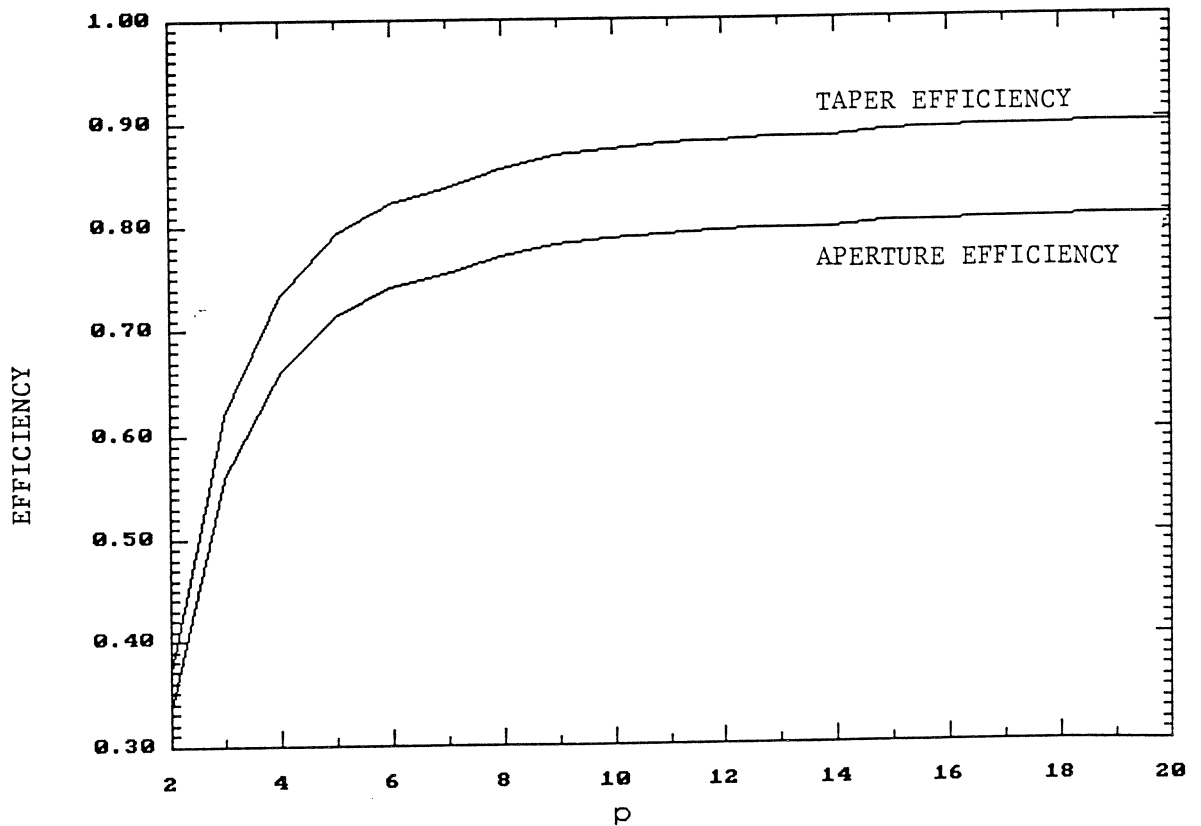
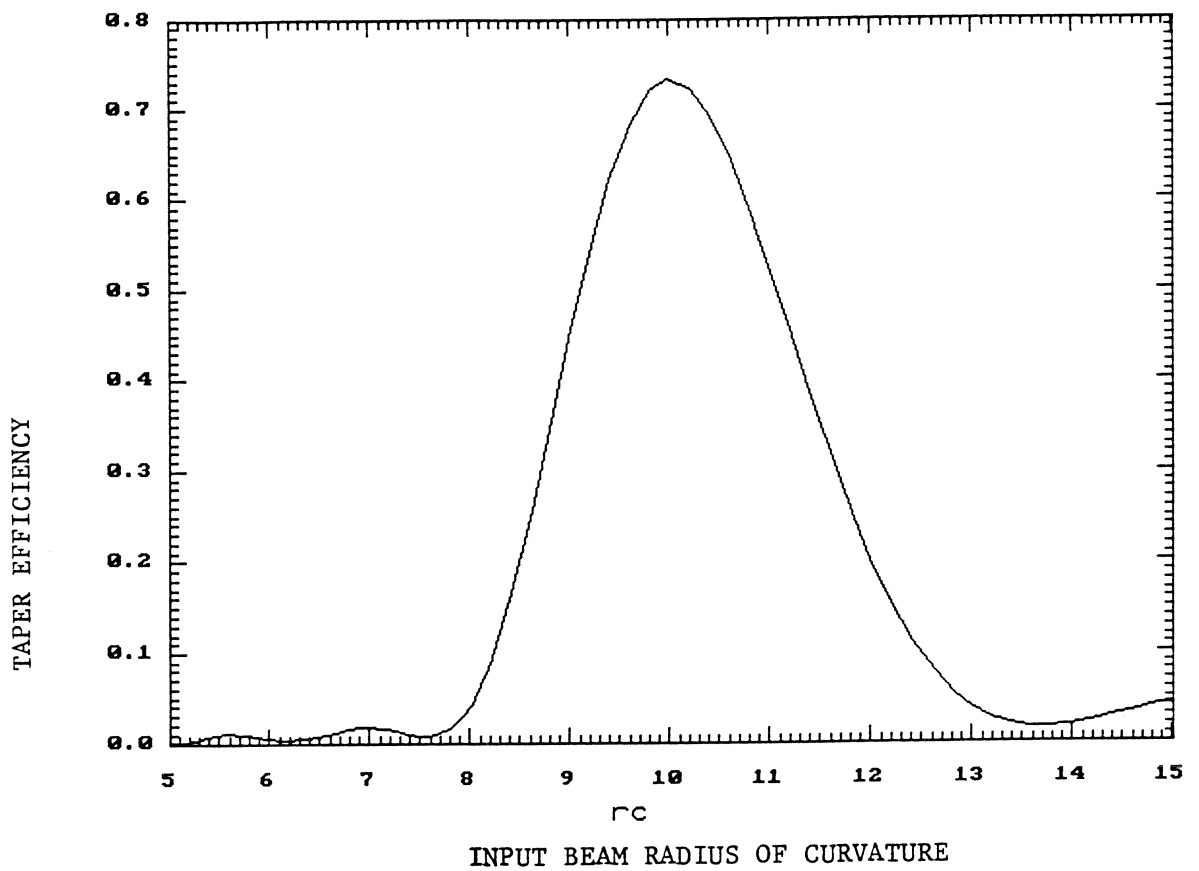

FIGURE 6 - (a) EFFICIENCY AS FUNCTION OF INPUT BEAM RADIUS OF CURVATURE
(b) EFFICIENCY VERSUS P

FIGURE 7
94GHz LENS COMPARISON

