

Heart-Rate and EKG Monitor Using the MSP430FG439

*Murugavel Raju**MSP430*

ABSTRACT

This application report describes how to build a digital heart-rate monitor using a MSP430FG439 microcontroller (MCU). The heartbeat rate per minute is displayed on an LCD. In addition, the application outputs a digital data stream via an RS232 serial port to allow EKG waveform display on a PC. PCB Gerber files, schematic, bill of materials, and firmware are provided in a zip file associated with this application report. The entire application runs using a CR2032 3-V lithium battery.

1 Introduction

An electrocardiogram (ECG), also called an EKG, is a graphic tracing of the voltage generated by the cardiac or heart muscle during a heartbeat. It provides very accurate evaluation of the performance of the heart.

The heart generates an electrochemical impulse that spreads out in the heart in such a fashion as to cause the cells to contract and relax in a timely order and, thus, give the heart a pumping characteristic. This sequence is initiated by a group of nerve cells called the sinoatrial (SA) node, resulting in a polarization and depolarization of the cells of the heart. Because this action is electrical in nature and the body is conductive with its fluid content, this electrochemical action can be measured at the surface of the body.

An actual voltage potential of approximately 1 mV develops between various body points. This can be measured by placing electrode contacts on the body. The four extremities and the chest wall have become standard sites for applying the electrodes. Standardizing electrocardiograms makes it possible to compare them as taken from person to person and from time to time from the same person. The normal electrocardiogram shows typical upward and downward deflections that reflect the alternate contraction of the atria (the two upper chambers) and of the ventricles (the two lower chambers) of the heart.

A typical single cardiac cycle waveform of a normal heartbeat is shown in [Figure 1](#). The voltages produced represent pressures exerted by the heart muscles in one pumping cycle. The first upward deflection, P, is due to atria contraction and is known as the atrial complex. The other deflections, Q, R, S, and T, are all due to the action of the ventricles and are known as the ventricular complexes. Any deviation from the norm in a particular electrocardiogram is indicative of a possible heart disorder.

In this application report, the EKG waveform is used by the MCU to measure the heartbeat rate. Because heartbeat calculation is the major focus the electrodes are simplified to two connections, one to a right arm and the other to the left arm. This type of setup can be frequently seen in exercise machines such as treadmills.

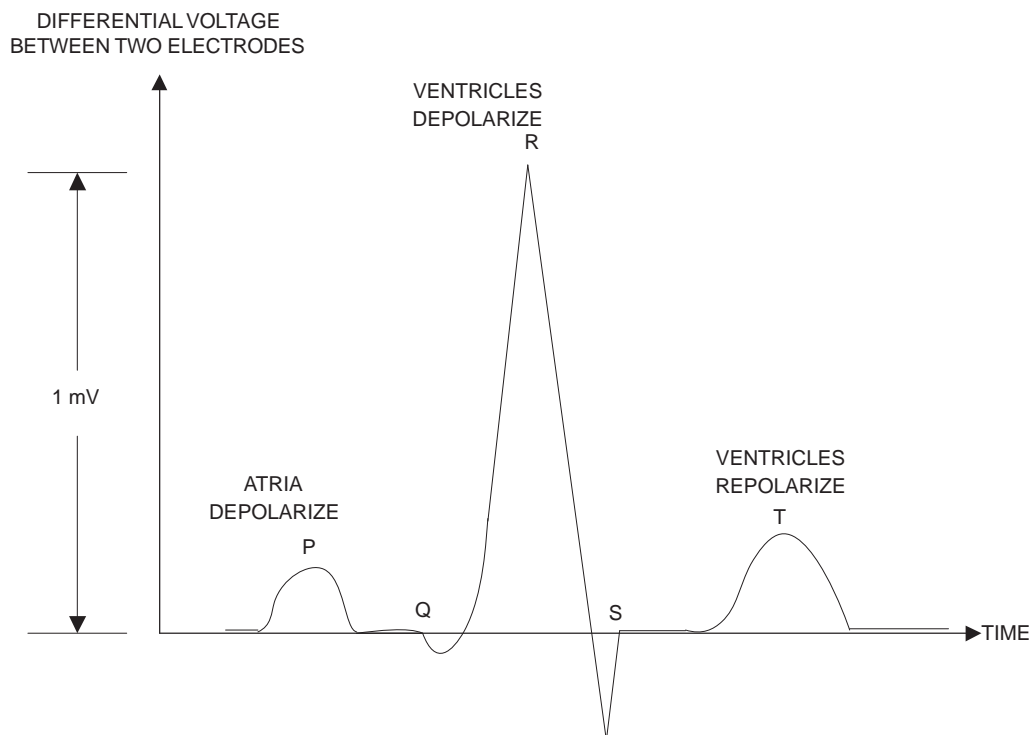

Figure 1. A Typical EKG Waveform

2 Circuit Description

The complete schematic diagram of this application is shown in [Figure 9](#).

2.1 Front-End Amplifier

The electrical signal derived from the electrodes is typically 1 mV peak-peak. An amplification of about 1000 \times is necessary to render this signal usable for heart-rate detection. Realizing clean amplification of the EKG signal with such high gain is no easy task given that the human body acts as a huge antenna that picks up a lot of noise, including a dominant 50-Hz/60-Hz line-frequency noise. This has to be filtered by a strong post filter after amplification. Unfortunately, any amplification amplifies the noise voltages in addition to the desired EKG signal. In certain situations, the noise can completely override the EKG and render the amplified signal useless.

A better approach is to use a differential amplifier. Thanks to the identical common mode signals from the EKG pick up electrodes, the common mode noise is automatically cancelled out using an ideally matched differential amplifier.

The differential amplifier used in the front end of this application is an INA321 instrumentation amplifier that has perfectly matched and balanced integrated gain resistors. This device is specified to operate with a minimum of 2.7-V single rail power supply. The INA321 provides a fixed amplification of 5 \times for the EKG signal. With its CMRR specification of 94 dB extended up to 3 kHz, the INA321 rejects the common-mode noise signals including the line frequency and its harmonics. The quiescent current of the INA321 is 40 μ A, and the shutdown mode current is less than 1 μ A.

2.2 EKG Amplifier

The EKG signal at the output of INA321 is further amplified by OA0, one of the three integrated operational amplifiers in the MSP430FG439. Figure 2 is the circuit diagram for the EKG amplifier front end.

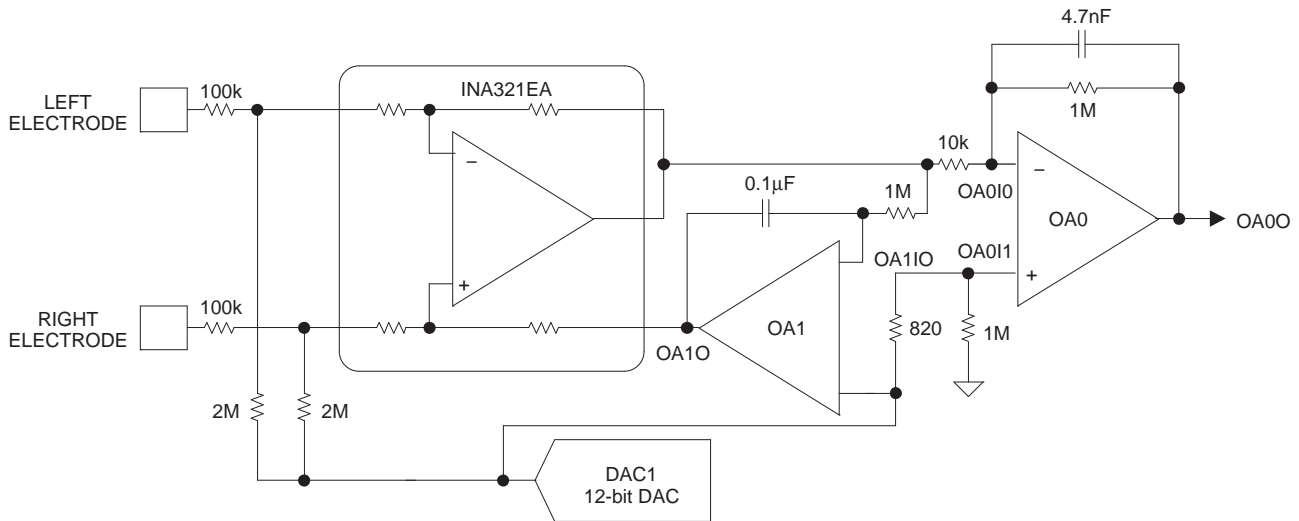

Figure 2. EKG Amplifier Circuit Diagram

Together with the OA0 amplification, the EKG signal is amplified to a total of 500 \times . Slight imbalances in electrode lengths and contacts cause the common-mode signal to offset, resulting in noise at the OA00 output. The line frequency content can be seen as a broad trace of the EKG signal as shown in Figure 3. The broadening is caused by the additive line frequency content over the EKG signal.

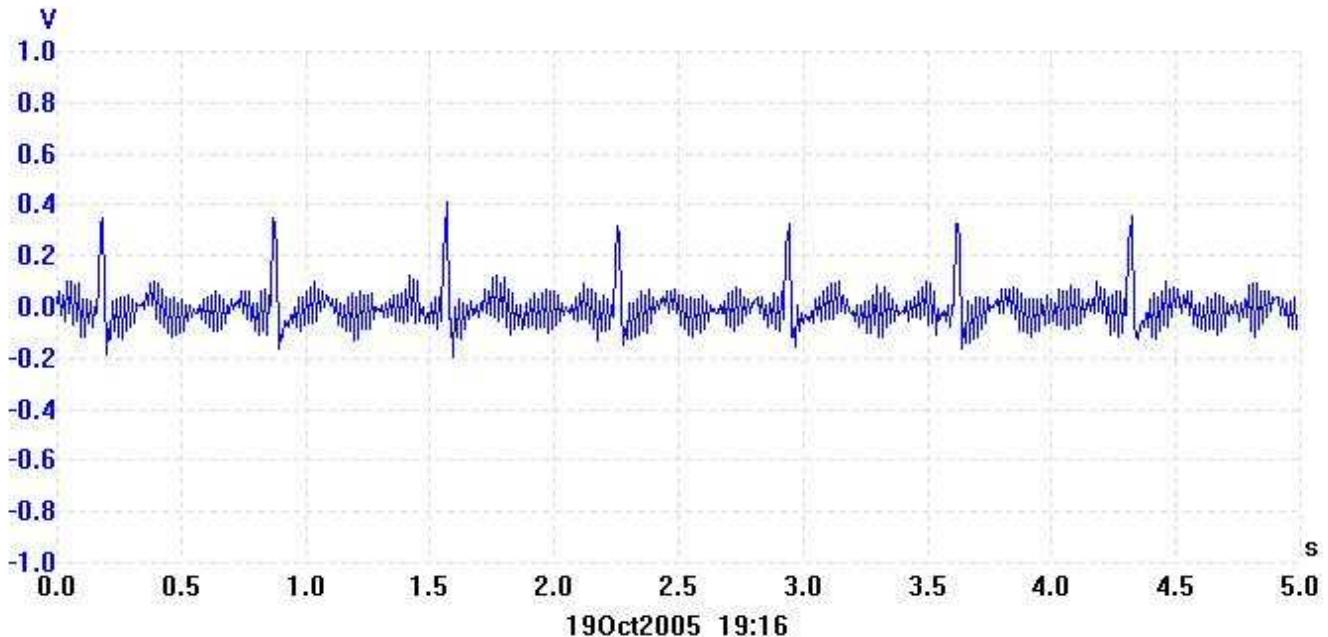

Figure 3. 500 \times Amplified EKG Signal With 60-Hz Noise Content

The 1-M Ω feedback resistor in parallel with a 4.7-nF capacitor in the OA0 section provides a high-frequency rolloff at about 250 Hz and serves as an anti-aliasing filter.

Because of the large amplification factor, the output is sensitive to the variations in electrode to skin contact resistance. This results in a variation of the dc content of the amplified differential signal and manifests itself as a drift in the baseline of the EKG. This is popularly called baseline wandering and often causes wavy traces of the EKG. This issue is managed by using an analog integrator scheme designed with OA1. The integrator integrates the dc content of the 5× amplified EKG and feeds it back to the INA321. The feedback allows the INA321 to maintain a constant DC level at the output, regardless of the change in skin contact resistance.

If this application is primarily used for EKG display and monitoring, the third operational amplifier, OA2, can be used as a unity gain buffer between the DAC1 output and the third electrode, which is often connected to the right leg (RL) or right side of the thorax of the individual whose EKG is monitored.

The DAC1 is one of the two integrated DAC12 12-bit digital-to-analog converters in the MSP430FG439. Using DAC1 allows the user to implement a digital baseline wandering scheme by appropriate software algorithm. This function is not implemented in this application report. Instead, DAC1 provides a constant midsupply voltage level as the bias for the amplifier chain.

3 Signal Processing and Heartbeat Detection

3.1 EKG Sampling

The amplified EKG signal is internally fed to the on-chip analog-to-digital converter ADC12 input channel A1. The ADC12 samples the EKG signal with a sampling frequency, f_{sample} , of 512 Hz. Precise sampling period is achieved by triggering the ADC12 conversions with the Timer_A pulses. Timer_A is clocked by ACLK, which is generated from the 32.768-kHz low-frequency crystal oscillator.

The fastest deflection in the EKG is in the 20-ms range and happens at the QRS complex. It is important to capture the QRS complex in its entirety for useful medical evaluation of the EKG waveform. Having a sampling frequency of 512 Hz, or sampling period of approximately 2 ms, captures at least 10 samples at the QRS complex and ensures that the QRS complex is fully digitized. The QRS complex also serves as a definite indicator for every heart beat, hence, it is necessary to have it captured for heartbeat rate calculation. The heartbeat rate itself is typically in the 60 to 200 beats per minute, or about 3 Hz to 4 Hz.

3.2 Filtering Line-Frequency Noise

The sampled EKG waveform contains some amount of superimposed line-frequency content. This line-frequency noise is removed by digitally filtering the samples. A 17-tap low-pass FIR filter with pass-band upper frequency of 6 Hz and stop-band lower frequency of 30 Hz is implemented in this application. The filter coefficients are scaled to compensate the filter attenuation and provide additional gain for the EKG signal at the filter output. This adds up to a total amplification factor of greater than 1000× for the EKG signal. [Figure 4](#) shows the EKG waveform at the output of the FIR filter.

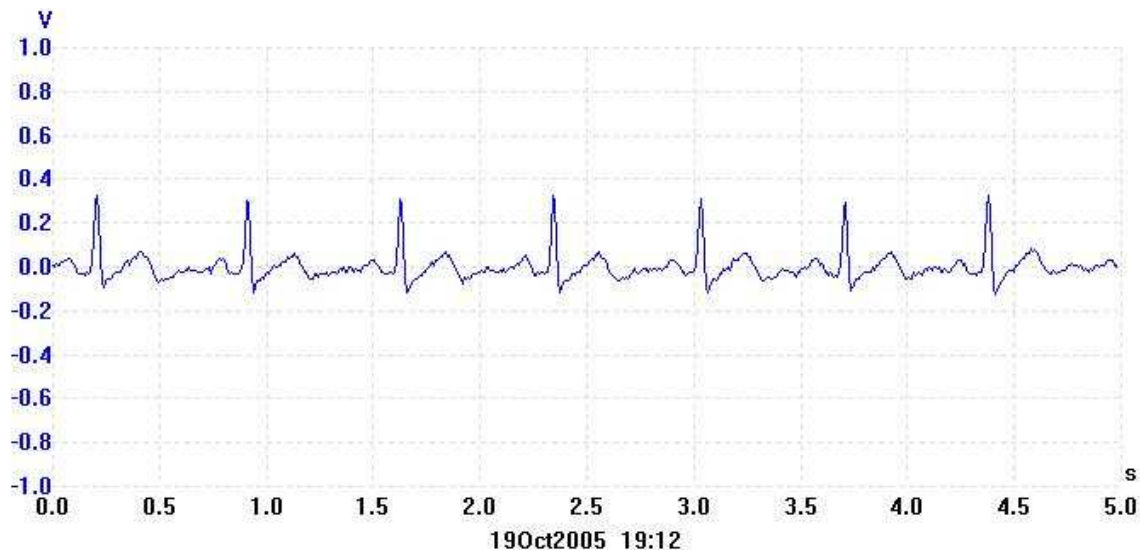

Figure 4. Low-Pass Filtered Waveform at DAC0 Output

The filtered samples can be output using the DAC0 in the MSP430 for analog reconstruction of the EKG waveform or can be streamed using the UART of the MSP430 at 115.2 kbps to be displayed on a PC screen.

3.3 Detecting QRS Complexes

In order to calculate the heartbeat accurately, the QRS complex must be detected for every beat. The QRS complex is the fast-rising portion of the EKG waveform. If the low-pass filtered samples of the EKG are differentiated or high-pass filtered, the QRS complex can be isolated for every beat. A 17-tap high-pass FIR filter with a corner frequency of 2 Hz is used in this application report. The filtered output is further processed by subtracting a fixed threshold from the filtered output. This cuts off the unwanted disturbances caused by the P and T waves and other movement-related artifacts. Using this method, the QRS complexes are discriminated from the complete EKG waveform. Figure 5 shows the signal that is output from the QRS discriminator to the input of the heartbeat detection and heart-rate calculation algorithm.

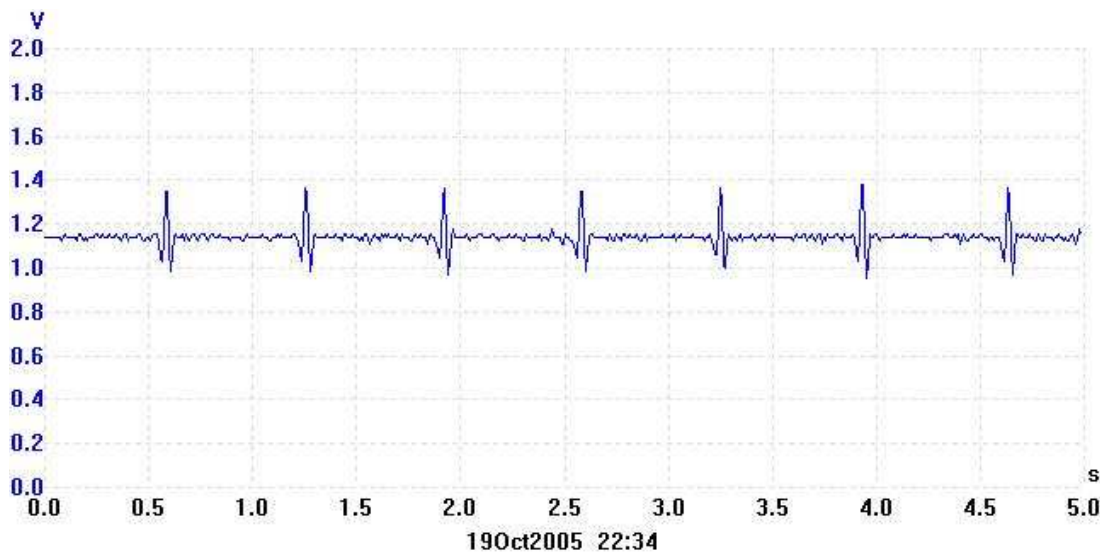

Figure 5. Discriminated QRS Waveform

3.4 FIR Filters

Linear phase symmetrical FIR filters are used in this application. Using symmetrical FIR filters reduces the demand on math multiplication operations to one half, because of the symmetrical nature of the filter coefficients. The filter results are rounded to 16 bits.

Figure 6 shows the magnitude versus frequency response curve for the low-pass filter used in this application. Note the amplification provided by the filter. This is achieved by multiplying all the coefficients by a constant.

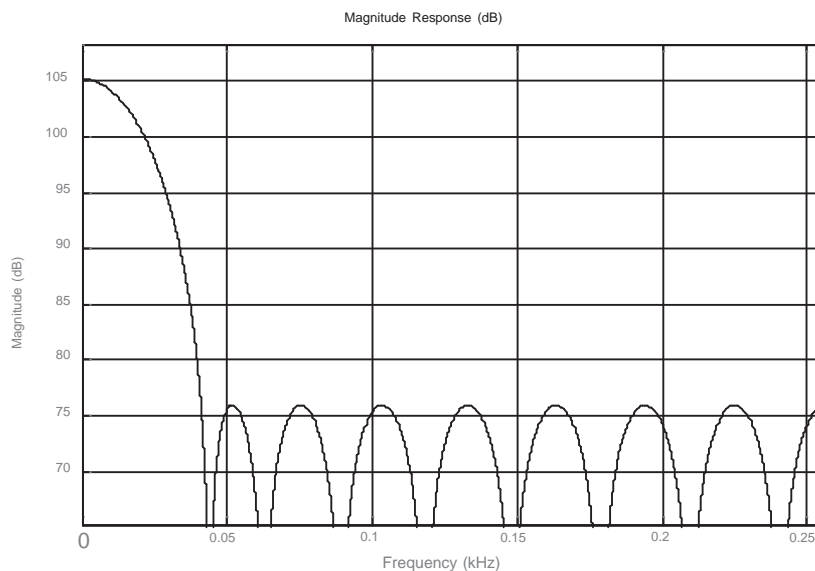

Figure 6. 17-Tap FIR Low-Pass Filter Magnitude vs Frequency Response

Figure 7 shows the magnitude versus frequency response curve for the high-pass filter used in this application. The filter coefficients were calculated using ScopeFIR, a filter designing and analyzing software tool from www.iowegian.com. Any other filter design tool, including MATLAB, can be used for designing the filters and calculating the coefficients.

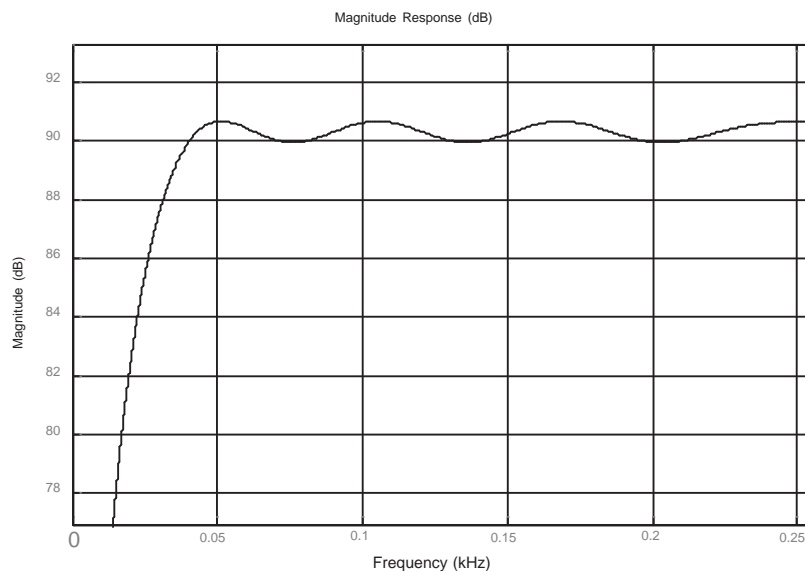

Figure 7. 17-Tap FIR High-Pass Filter Magnitude vs Frequency Response

3.5 Calculating Heartbeat Rate

The number of heart beats per minute is calculated using a three beat average. Two variables in the C main function, counter and pulseperiod, accurately track the time scale. Each output sample from the QRS discriminator is compared against a set threshold to detect the presence of a beat. Pulseperiod is incremented by one during every sample period. Because each sample occurs every 1/512 second, it is easy to track the time scale based on the number of counts in the pulseperiod variable. A 128-sample time window is used as a debounce time using counter. Every time a beat is detected, counter is reset and the LCD icon with four arrows is turned on to represent the heart beat. If a beat is not detected for 128 consecutive samples, a separation between successive beats is identified and the LCD icon with four arrows is turned off.

The pulseperiod is accumulated for three consecutive beats. On the third beat, pulseperiod is used for the calculation of heart-rate per minute and reset.

$$\text{Heartbeat rate per minute} = 1/[\text{pulseperiod}/(3 \times 512 \times 60)] = 92160/\text{pulseperiod}$$

4 Software

The software for this application is written in C using IAR Embedded Workbench Kickstart edition, available for free download from the MSP430 web page. The source code for reproducing this application is provided in a zip file available for download along with this application report. The software uses a dedicated 16×16 bit signed multiply routine written in assembly language for faster execution of the FIR filter calculations compared to the native C math library multiplication function. This function is called from the main C program using the syntax `long mul16(register int x, register int y)`.

Three C source files ("Heart rate.c", "Heart rate with DAC output.c", and "Heart rate with EKG Demo.c") are provided in the zip file. The names of these files signify their functionality.

The project must include the C source file as per the required functionality and the mul.s43 assembler source file for proper compilation.

The memory usage for the complete heart-rate with EKG project is 1168 bytes of code memory, 225 bytes of data memory and 64 bytes of const memory. This is only about one-fourth of the 4-Kbyte limit of the free C compiler in the IAR Embedded Workbench Kickstart edition.

The CPU runs at 2.097152 MHz using the FLL to source MCLK. The entire EKG program, including the FIR filters, QRS detection, and heart-rate calculation, uses about 1 MIPS of the CPU bandwidth.

5 Testing the Application

Two square pads, one on the top layer and the other on the bottom layer of the double sided PCB, are provided on either side of the LCD to serve as right and left hands contact electrodes. When in use, the power jumper PWR must be installed, and the board must be held using both hands by placing the thumb and index fingers of each hand on the square pads. Care must be taken not to touch any other electrical areas of the PCB. A good way is to keep the hold towards the edges of the board. The contact resistance between the fingers and the square pads must be low for good signal quality. A little bit of moisturizer spread and rubbed over the fingers helps users with dry skin. [Figure 8](#) shows the picture of the EKG board in action.



Figure 8. Picture of EKG Board in Action

Note: This application design is published for reference purpose only and not intended for any life-saving or medical monitoring use.

5.1 PC Scope EKG Display

When using the "Heart rate with EKG Demo.c" program, an RS-232 level shifter is required between the EKG board and a PC. Only the TX line P2.4/UTXD0 is required, because no handshake is used for the serial communication. The baud rate of the serial communication to the PC is 115.2 kbps.

For displaying EKG, the PC must run scope.exe using command line option of Windows. The scope.exe is an open source PC application program. For convenience, this application program is provided in the oscilloscope.zip file under the source files along with this application report.

Figure 9 shows the screen capture of the EKG display using the PC Scope application program.

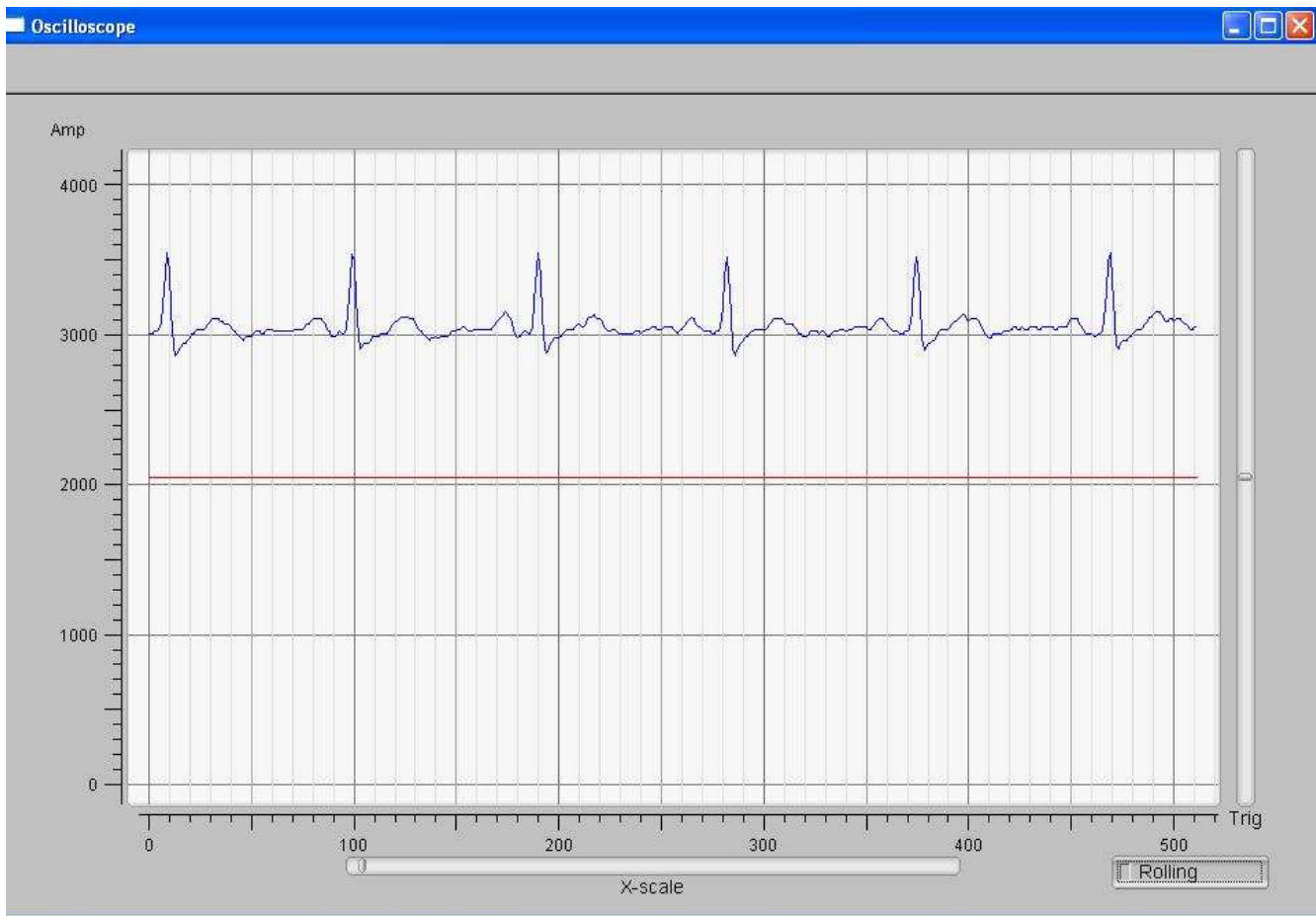

Figure 9. PC Scope Program EKG Display

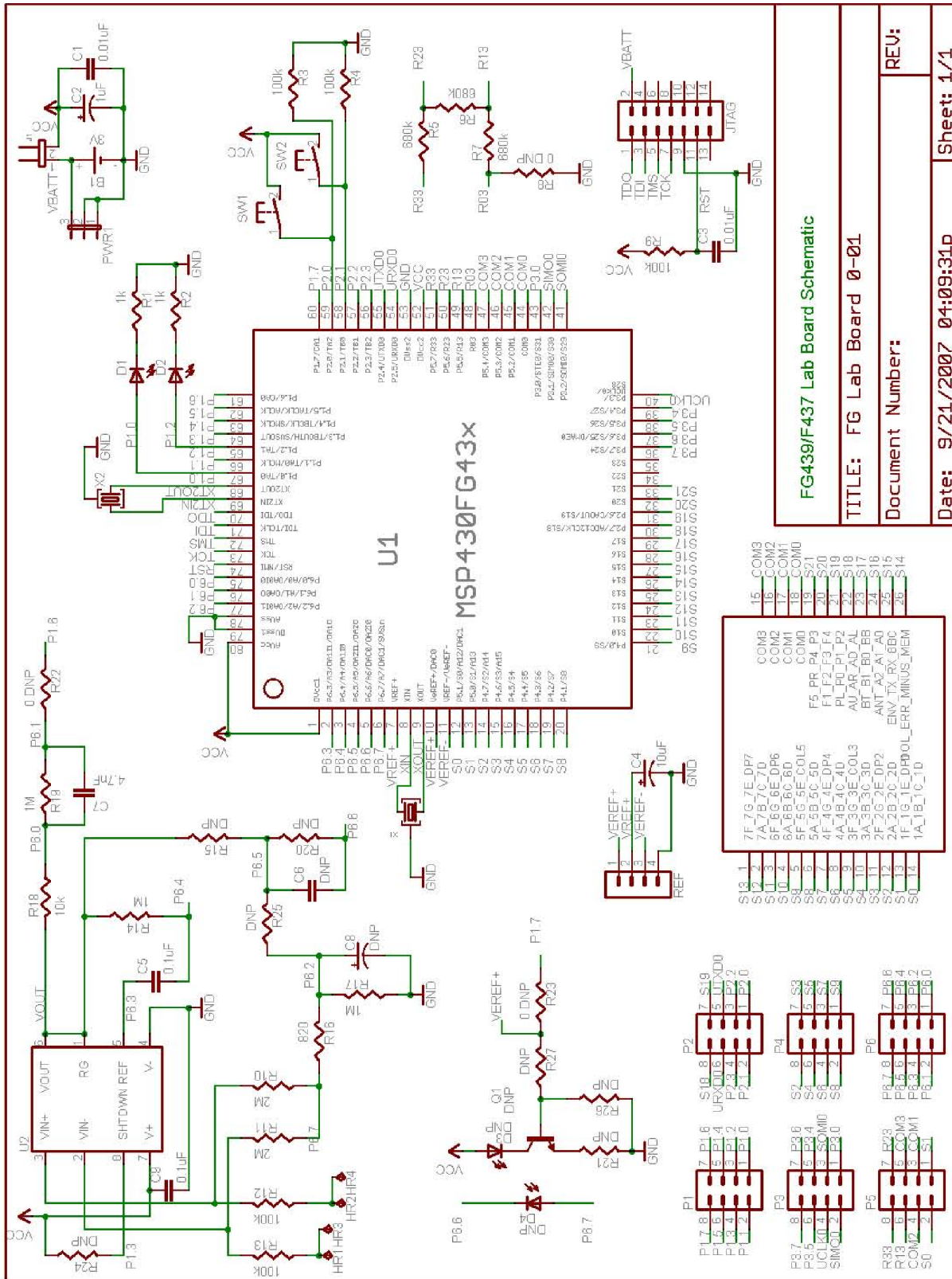

Figure 10. Schematic Diagram

FG439/F437 Lab Board Schematic

TITLE: FG Lab Board 0-01

Document Number:

REV:

Date: 9/21/2007 04:09:31p

Sheet: 1/1

6 References

- *MSP430x4xx Family User's Guide* ([SLAU056](#))
- MSP430FG439 Mixed Signal Microcontroller data sheet ([SLAS380](#))
- INA321 microPower Single-Supply CMOS Instrumentation Amplifier data sheet ([SBOS168](#))
- *Digital Filters Design* www.iowegian.com
- *Introduction to Medical Electronics*, Burton R. Klein

IMPORTANT NOTICE

Texas Instruments Incorporated and its subsidiaries (TI) reserve the right to make corrections, modifications, enhancements, improvements, and other changes to its products and services at any time and to discontinue any product or service without notice. Customers should obtain the latest relevant information before placing orders and should verify that such information is current and complete. All products are sold subject to TI's terms and conditions of sale supplied at the time of order acknowledgment.

TI warrants performance of its hardware products to the specifications applicable at the time of sale in accordance with TI's standard warranty. Testing and other quality control techniques are used to the extent TI deems necessary to support this warranty. Except where mandated by government requirements, testing of all parameters of each product is not necessarily performed.

TI assumes no liability for applications assistance or customer product design. Customers are responsible for their products and applications using TI components. To minimize the risks associated with customer products and applications, customers should provide adequate design and operating safeguards.

TI does not warrant or represent that any license, either express or implied, is granted under any TI patent right, copyright, mask work right, or other TI intellectual property right relating to any combination, machine, or process in which TI products or services are used. Information published by TI regarding third-party products or services does not constitute a license from TI to use such products or services or a warranty or endorsement thereof. Use of such information may require a license from a third party under the patents or other intellectual property of the third party, or a license from TI under the patents or other intellectual property of TI.

Reproduction of TI information in TI data books or data sheets is permissible only if reproduction is without alteration and is accompanied by all associated warranties, conditions, limitations, and notices. Reproduction of this information with alteration is an unfair and deceptive business practice. TI is not responsible or liable for such altered documentation. Information of third parties may be subject to additional restrictions.

Resale of TI products or services with statements different from or beyond the parameters stated by TI for that product or service voids all express and any implied warranties for the associated TI product or service and is an unfair and deceptive business practice. TI is not responsible or liable for any such statements.

TI products are not authorized for use in safety-critical applications (such as life support) where a failure of the TI product would reasonably be expected to cause severe personal injury or death, unless officers of the parties have executed an agreement specifically governing such use. Buyers represent that they have all necessary expertise in the safety and regulatory ramifications of their applications, and acknowledge and agree that they are solely responsible for all legal, regulatory and safety-related requirements concerning their products and any use of TI products in such safety-critical applications, notwithstanding any applications-related information or support that may be provided by TI. Further, Buyers must fully indemnify TI and its representatives against any damages arising out of the use of TI products in such safety-critical applications.

TI products are neither designed nor intended for use in military/aerospace applications or environments unless the TI products are specifically designated by TI as military-grade or "enhanced plastic." Only products designated by TI as military-grade meet military specifications. Buyers acknowledge and agree that any such use of TI products which TI has not designated as military-grade is solely at the Buyer's risk, and that they are solely responsible for compliance with all legal and regulatory requirements in connection with such use.

TI products are neither designed nor intended for use in automotive applications or environments unless the specific TI products are designated by TI as compliant with ISO/TS 16949 requirements. Buyers acknowledge and agree that, if they use any non-designated products in automotive applications, TI will not be responsible for any failure to meet such requirements.

Following are URLs where you can obtain information on other Texas Instruments products and application solutions:

Products

| | |
|-----------------------------|--------------------------------------------------------------------|
| Amplifiers | amplifier.ti.com |
| Data Converters | dataconverter.ti.com |
| DSP | dsp.ti.com |
| Clocks and Timers | www.ti.com/clocks |
| Interface | interface.ti.com |
| Logic | logic.ti.com |
| Power Mgmt | power.ti.com |
| Microcontrollers | microcontroller.ti.com |
| RFID | www.ti-rfid.com |
| RF/IF and ZigBee® Solutions | www.ti.com/lprf |

Applications

| | |
|--------------------|--------------------------------------------------------------------------|
| Audio | www.ti.com/audio |
| Automotive | www.ti.com/automotive |
| Broadband | www.ti.com/broadband |
| Digital Control | www.ti.com/digitalcontrol |
| Medical | www.ti.com/medical |
| Military | www.ti.com/military |
| Optical Networking | www.ti.com/opticalnetwork |
| Security | www.ti.com/security |
| Telephony | www.ti.com/telephony |
| Video & Imaging | www.ti.com/video |
| Wireless | www.ti.com/wireless |

Mailing Address: Texas Instruments, Post Office Box 655303, Dallas, Texas 75265
Copyright © 2008, Texas Instruments Incorporated