

INSTRUMENTATION AND TESTING OF SUBMILLIMETER WAVE COMPACT ANTENNA TEST RANGES

**Jussi Säily, Juha Ala-Laurinaho, Janne Häkli, Jussi Tuovinen*,
Arto Lehto, Antti V. Räisänen**

MilliLab, Radio Laboratory, Helsinki University of Technology

P.O. Box 3000, FIN-02015 HUT, Finland

*MilliLab, VTT Information Technology

P.O. Box 1202, FIN-02044 VTT, Finland

Email: Jussi.Saily@hut.fi

Abstract

Testing of antennas in submillimeter wave (>300 GHz) compact antenna test ranges (CATRs) has some specific problems that do not appear with conventional millimeter wave CATRs. The available transmitter power is very low, usually in the range of a few milliwatts. Also, the atmospheric attenuation due to water vapour absorption at certain frequency bands can be very high. For these reasons the CATR should be located inside a controlled, low humidity atmosphere. Furthermore, at submm wavelengths the required quiet-zone quality is more difficult to achieve than at mm wavelengths. A hologram is seen as a feasible alternative to reflectors as the collimating element in a CATR. In this paper, the proposed testing environment using a hologram CATR along with the needed instrumentation for 300–1000 GHz are presented. The results apply also to reflector CATRs.

1. Introduction

Planned satellite missions in the next 10–15 years will have spaceborne millimeter and submillimeter wave radiotelescopes and instruments. The European Space Agency (ESA) has several missions for scientific research (FIRST, PLANCK) and atmospheric limb sounding (MASTER, SOPRANO, PIRAMHYD). The diameters of the reflector antennas are from 0.5 to 3.5 meters and they will operate in the frequency range of 200–3000 GHz. However, there are no verified test ranges for antenna diameters over 1 m at frequencies over 300 GHz.

Far-field distances of electrically large antennas at 1 THz can be tens of kilometers, so conventional outdoor and indoor far-field measurements are ruled out by the high atmospheric attenuation and signal distortion. The most feasible alternatives are the near-field scanning method and the compact antenna test ranges. Both of these allow measurements to be done inside a controlled environment with constant temperature and humidity. The near-field method requires a measurement time of several days for electrically large antennas at THz frequencies, and it is not practical due to the inherent instrument instabilities. The study

presented in [1] indicates that the compact range principle is the most feasible method at submillimeter wavelengths.

The CATR uses a collimating element to transform a spherical wave into a plane wave. The CATR enables direct measurement of the antenna far-field pattern with relatively small distances between the signal source and the receiver, thus with little attenuation. The collimator can be a reflector, a lens, or a hologram. Reflector CATRs have been used up to 200 GHz and their highest operating frequency is limited by the surface inaccuracies of the reflectors [2]. The surfaces of the large antennas to be tested are made already as smooth as possible and to accurately test these, the collimating reflector should be 20–30% larger in size and also have a considerably better surface accuracy. This is clearly very costly even if it can be done. The CATR based on a foam lens is not feasible at submm wavelengths due to manufacturing and material difficulties.

A new type of CATR based on a hologram has been developed at the HUT Radio Laboratory to overcome the very stringent surface accuracy demands of the reflectors at high frequencies [3,4]. Figure 1 shows the hologram CATR operating principle and a typical hologram pattern.

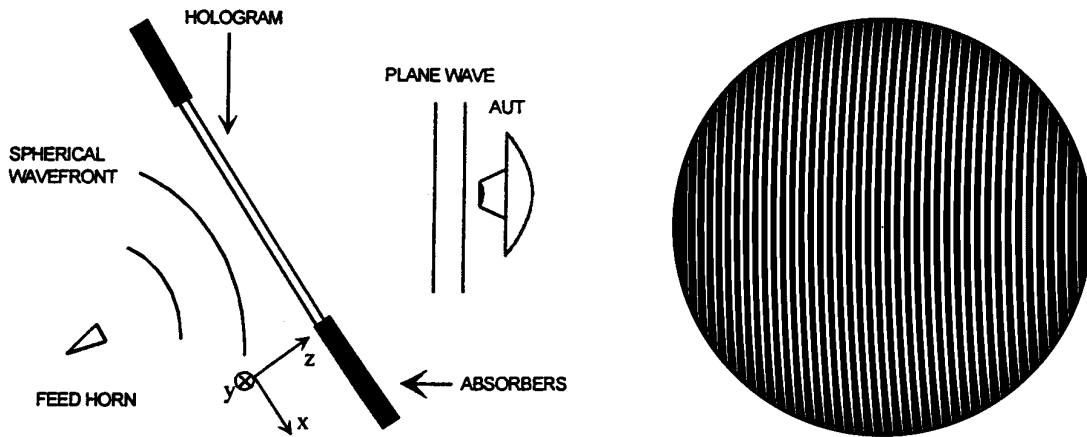

Figure 1. Operating principle of the hologram CATR and a typical hologram pattern.

In a recent project to study the hologram performance at submm wavelengths, a demonstrator CATR based on a 60 cm diameter hologram was constructed and tested at 310 GHz. Test results for this CATR are presented in [5] and [6]. The measured and simulated quiet-zone fields of the CATR were very similar. The quiet-zone area with peak-to-peak amplitude and phase ripples of 1.0 dB and 10 degrees, respectively, was about 25x20 cm². The instrumentation and testing environment presented in this paper apply to all CATRs at short submm wavelengths, but the hologram CATR is used as the primary topology.

2. Testing environment for submillimeter wave hologram CATRs

Water vapour is the most significant source of atmospheric attenuation in the antenna test range. It has several strong absorption bands in the millimeter and submillimeter wavelengths, as shown in Figure 2 for two different water vapour concentrations [1]. The strong attenuation at these bands is caused by the excitation of certain molecular rotational modes. The observed bands are centered around the molecular rotational frequencies of water and their widths are determined by the total air pressure (with only a weak temperature dependence). The integrated band-strengths are determined by the water vapour concentration in the air [1].

The other major atmospheric gas molecules include nitrogen, carbon dioxide, and oxygen. Nitrogen and carbon dioxide have zero electrical and magnetic dipole-moments and they do not directly attenuate THz signals. Oxygen has also zero electrical dipole-moment, but a non-zero magnetic dipole-moment, which results in a few oxygen-related absorption bands in the THz range. Oxygen-related absorption is much weaker than the water vapour absorption. However, all gas molecules affect the air pressure and thus contribute to the widening of the absorption bands [1].

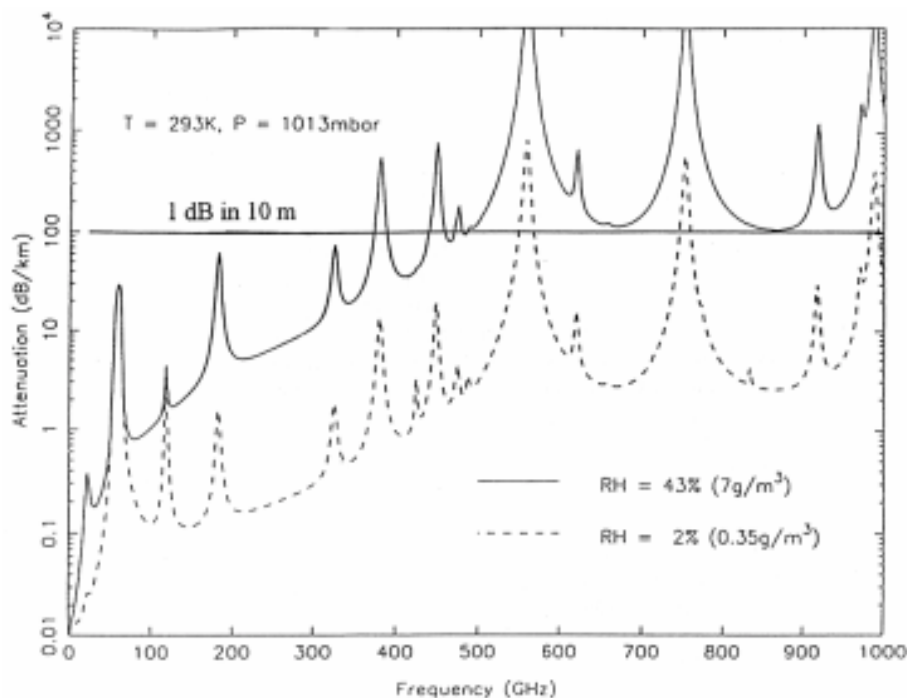

Figure 2. Atmospheric attenuation as a function of frequency for two different water vapour concentrations.

Another problem related to atmospheric water vapour is the variation of the phase-delay of a signal beam in time or in space [1]. In a CATR facility, the variations of phase-delay in time do not have significant effect on the measurement of antenna power pattern. Instead, spatial variations in the refractive index of the air could distort the measurement, because they could spoil the planarity of the plane-wave phase-front in the quiet-zone. This effect is minimised by keeping the water vapour concentration as low as possible.

It is clearly desirable to enclose the THz CATR in a tightly controlled environment in order to reduce the absorption to an acceptable level. The controlled parameters are temperature and water vapour concentration. These parameters must remain stable over the measurement period and the test room volume. The antennas-under-test (AUTs) can normally be tested in normal room temperature of 290 K. This temperature will be used for convenience at submm wavelengths also, since cooling of the atmosphere does not decrease the signal attenuation. Possible cryogenic receivers associated with AUTs will have their own cooling systems.

A perfect vacuum inside the CATR enclosure would be advantageous with respect to atmospheric attenuation, but the required large size of the enclosure makes this impractical. However, the costs of obtaining lower attenuation should be weighted against the cost of increasing the transmitted power. At THz frequencies, the power levels are low and are usually very costly to increase.

The most cost-effective way to reduce the attenuation to an acceptable level is to lower the water vapour concentration of the testing atmosphere. According to [1], the atmospheric attenuation should be below 1 dB/10 m (shown as the horizontal line in Figure 2). The higher curve shown in Figure 2 is calculated for water vapour concentration of 7 g/m^3 ($T=293 \text{ K}$ and $P=1013 \text{ mbar}$). This humidity level can be obtained in a normal laboratory room with air conditioning. The lower curve with water vapour concentration of 0.35 g/m^3 needs a sealed dry-cabinet with a circulating-air drying system. The required hermetic enclosure and the drying system increase the cost of the facility. The cost estimate for a 1000 m^3 sealed cabinet with driers is about 750 000 USD.

Figure 3 shows one possible layout for the hologram CATR enclosure. The CATR is designed for the testing of the ESA ADMIRALS reflector antenna. The diameter of the antenna is about 2 meters. For a quiet-zone diameter of 2.5 meters, a hologram diameter of about 4 meters is required. Separation between the source and receiver in this facility is around 24 meters. The floor size of the planned enclosure excluding the control, air conditioning and air-lock rooms is 170.5 m^2 . The height of the room should be about 6 meters, making the volume of the enclosure 1023 m^3 .

The control room is situated near the source system, because the used vector network analyzer should be placed near the source. Two access doors through air-locks are provided into the enclosure, one for the source and the other for the AUT and receiver. Air conditioning is placed in the middle for maximum drying efficiency. The temperature inside the chamber is kept constant but it is not possible to cool it to cryogenic temperatures.

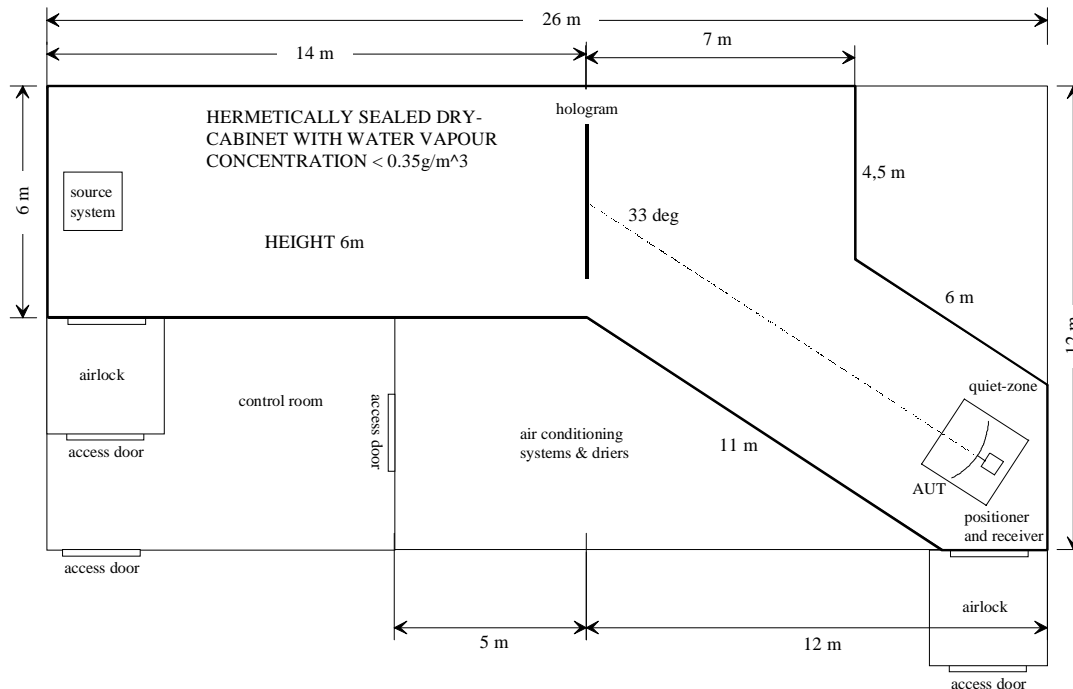

Figure 3. Schematic layout of the 2.5 meter quiet-zone hologram CATR.

The CATR facility needs large quantities of high-quality, broadband radar absorbing material (RAM) to prevent reflections from the walls and the hologram frame. The requirements for a suitable absorbing material include -40 dB reflection coefficient in all angles of incidence, low evolution of dust and water vapour, light weight, and durability. Suitable RAM panels are available from at least two commercial suppliers, but they are very expensive compared to conventional millimeter wave materials. The cost of the absorbers will be so high that preferably a single type of absorber covers the whole frequency band of the CATR. The costs can be reduced by using absorbers of lesser quality in the not-so-critical areas. Only the source system, the hologram frame, the AUT positioner and the wall absorbing the unwanted diffracted fields from the hologram need to be covered with the best possible RAM material.

3. Instrumentation for 300–1000 GHz

The required instrumentation for the submillimeter wave CATR include a signal source, a receiver, a measurement controller (vector network analyzer), and the feed and AUT positioners. A planar xy -scanner is also needed to verify the quiet-zone amplitude and phase quality periodically. Our laboratory uses as the measurement controller a dedicated submillimeter wave vector network analyzer MVNA-8-350 manufactured by AB Millimetre in France. The MVNA is easily adaptable to different frequency bands by changing the source and receiver as required. Our laboratory has used phase-locked Gunn oscillators and

BWOs (backward-wave oscillators) as the source and a Schottky diode mixer pumped by a Gunn-oscillator as the receiver.

The most feasible source oscillators for THz CATR operation are frequency multiplied InP-Gunn oscillators and BWOs. Far-infrared (FIR) lasers have higher powers but they are very large-sized and difficult to tune in frequency. In order to obtain high enough dynamic range in the CATR quiet-zone verification procedure, a relatively high-power transmitter is needed. Frequency multiplied Gunn oscillators have very small output powers at THz frequencies, a few μW maximum, due to the low efficiency of the multipliers. Also, the electrical tuning range of Gunn oscillators is quite small. Advantages of the Gunn oscillators are the relatively low cost, reliability and small size when compared to the BWOs. Figure 4 shows the phase-locked Gunn oscillator source used at MilliLab for 300–1000 GHz.

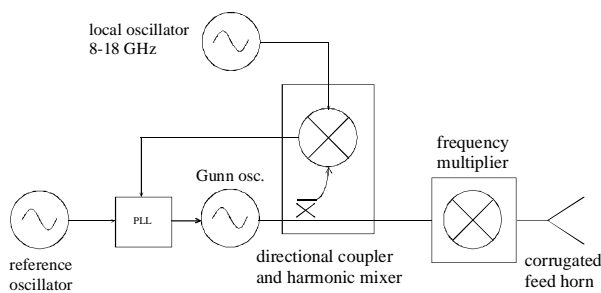

Figure 4. Phase-locked Gunn source for 300-1000 GHz (ABmm ESA-1).

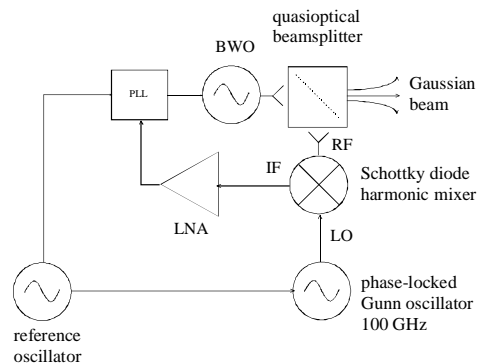

Figure 5. Phase-locked BWO source for 300-1000 GHz (MilliLab).

Wideband BWOs have 1 mW typical output power at 1 THz, and the power can be controlled electrically with the heating current. Narrowband BWOs can have power levels of tens of mWs at the same frequencies, but are not commercially available. Disadvantages of BWOs are the large size and weight of the device, high cost of the tube, the required stable high-voltage supply, and the relatively small lifetime of the tube (typically 1000 hours at high output power levels). However, the BWOs are very suitable for operation in CATRs because the high power level is only needed for relatively short periods during the quiet-zone verification and optimization procedures. When testing a large-sized high-gain telescope antenna, only a small fraction of the available power is needed to saturate the receiver. The lifetime of the tube operated at low power level is expected to increase many times from the 1000 hours.

At MilliLab, phase-locking of a submillimeter wave BWO has been demonstrated at 310 GHz. A similar arrangement shown in Figure 5 will be used for THz operation. A

quasioptical beamsplitter is used to couple a small fraction of the output power to a sensitive Schottky mixer for downconversion. The local oscillator frequency for the mixer is chosen so, that the IF frequency will be at the PLL reference frequency.

A sensitive heterodyne receiver is needed for the periodical quiet-zone verification procedure and for measuring AUTs which are not tested with their dedicated receivers. The submillimeter wave head of the receiver should be small-sized and lightweight since it is to be mounted on a *xy*-scanner. A suitable heterodyne receiver used at MilliLab with the MVNA is shown in Figure 6. The receiver consists of a whisker-contacted Schottky diode downconversion mixer pumped by a phase-locked Gunn oscillator and a baseband vector receiver. The detection bandwidth of the vector receiver can be as narrow as 10 Hz, so very high dynamic range is obtained. High dynamic range reduces the detected amplitude and phase variations, resulting in increased measurement accuracy.

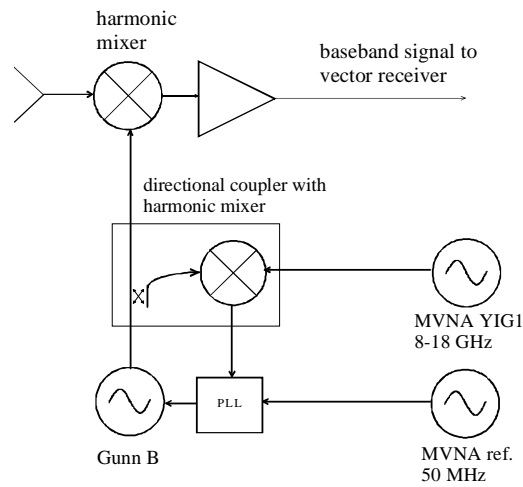

Figure 6. Heterodyne receiver for 300–1000 GHz (ABmm ESA-2).

4. Conclusions

Accurate antenna testing at high submillimeter wavelengths is considerably more demanding than at millimeter waves. The compact antenna test range principle is seen as the most feasible method at these frequencies. However, the manufacturing of the needed large-sized holograms and reflectors with high surface accuracies is difficult and very costly.

Problems in instrumentation and testing of submm wavelength CATRs were discussed in this paper, along with possible solutions. The very large atmospheric attenuation due to water vapour in a normal laboratory room air completely blocks out the most important frequency

bands. The most cost-effective and feasible method is to incorporate the CATR in a hermetically sealed cabinet with a circulating-air drying system.

Acknowledgements

This project is partially supported by ESA ESTEC (ESTEC Contract No. 13096/98/NL/SB), TEKES (Finland) and the Academy of Finland. The authors would also like to thank Mr. Eino Kahra, Mr. Lauri Laakso and Mr. Lorenz Schmuckli from the Radio Laboratory workshop for valuable help with the various mechanical constructions.

References

- [1] Foster, P.R., Martin, D., Parini, C., Räisänen, A., Ala-Laurinaho, J., Hirvonen, T., Lehto, A., Sehm, T., Tuovinen, J., Jensen, F., Pontoppidan, K., "Mmwave antenna testing techniques - Phase 2", 1996, *MAAS Report 304*, 224 p.
- [2] Habersack, J., Lindemer, W., Steiner, H.-J., "High performance mm-wave measurements up to 200 GHz in the compensated compact range", *Proc. 2nd ESA Workshop on Millimetre Wave Technology and Applications: Antennas, Circuits and Systems*, Espoo, Finland, May 1998, pp. 529–535.
- [3] Tuovinen, J., Vasara, A., Räisänen, A., "A new type of compact antenna test range", *Proc. 22nd European Microwave Conference*, Espoo, Finland, Aug. 1992, pp. 503–508.
- [4] Hirvonen, T., Ala-Laurinaho, J., Tuovinen, J., Räisänen, A., "A compact antenna test range based on a hologram", *IEEE Trans. on Antennas and Propagation*, Vol. 45, No. 8, Aug. 1997, pp. 1270–1276.
- [5] Säily, J., Ala-Laurinaho, J., Häkli, J., Tuovinen, J., Lehto, A., Räisänen, A.V., "Development of a 310 GHz hologram compact antenna test range", *Proc. 21st Annual Meeting & Symposium of the AMTA*, Monterey, CA, USA, Oct. 1999, pp. 464–469.
- [6] Säily, J., Ala-Laurinaho, J., Häkli, J., Tuovinen, J., Lehto, A., Räisänen, A.V., "Test results of 310 GHz hologram compact antenna test range", *Electronics Letters*, Vol. 36, No. 2, Jan. 20th, 2000, pp. 111–112.