

'Additive-Angle' Method for Fast Large-Tip-Angle RF Pulse Design in Parallel Excitation

W. A. Grissom¹, J. A. Fessler², and D. C. Noll¹

¹Biomedical Engineering, University of Michigan, Ann Arbor, Michigan, United States, ²Electrical Engineering, University of Michigan, Ann Arbor, Michigan, United States

INTRODUCTION: Most methods for the design of RF pulses in parallel excitation use the linear small-tip-angle approximation, which provides computationally efficient RF pulse calculation. However, pulses designed using these methods produce distorted excitation patterns at large tip angles, due to non-linearity of the Bloch equation (1). One method has been introduced for large-tip-angle pulse design in parallel excitation (2), however this method suffers from long computation time. In this work, we introduce a fast method for large-tip-angle RF pulse design in parallel excitation that employs the small-excitation approximation (3) to iteratively update an initial RF pulse to correct for distortions predicted by Bloch equation simulation.

METHODS: Our method is formulated as a problem of designing many small-tip-angle pulses that add to produce an accurate large-tip-angle pulse. Similar methods have been introduced for 1D pulse design up to 60° flip angles (4,5), and up to 180° flip angles when pulses are constrained to be time-symmetric (6). Here we generalize to multidimensional parallel excitation, and introduce a modification to these methods that allows us to reach flip angles of 180° without a time-symmetry constraint. Given a desired flip angle pattern ϕ_{des} , we design initial RF pulses via the method in (7):

$$\hat{\mathbf{b}}_{full} = \underset{\mathbf{b}_{full}}{\operatorname{argmin}} \left\{ \|\mathbf{A}_{full} \mathbf{b}_{full} - \phi_{des}\|_{\mathbf{W}}^2 + \beta \|\mathbf{b}_{full}\|^2 \right\}, [1]$$

where \mathbf{b}_{full} is a vector containing the pulses for each coil, \mathbf{A}_{full} is a system matrix containing Fourier matrices that are weighted in the spatial dimension by each coil's transmit sensitivity, \mathbf{W} is a diagonal matrix that specifies a region of interest (ROI), and β is a Tikhonov regularization parameter. The solution is computed using conjugate gradient with non-uniform fast Fourier transforms to compute products involving \mathbf{A}_{full} (8). An initial RF pulse is designed, and then simulated with an exact Bloch equation simulator. The result of Bloch simulation is then used to form a new desired pattern based on the difference in flip angle between the excited and desired pattern:

$$\phi_{new} = \Delta(\phi_{des} - \phi_{Bloch}) e^{i\angle M_{xy,Bloch}}, [2]$$

where Δ is a step size, and $\phi_{Bloch} = \cos^{-1} M_{z,Bloch}$. The phase of the previous pulse's transverse excitation is included to ensure that the previous and new pulses produce a rotation about the same (transverse-plane) vector, and may be added. We find that this prevents the method from diverging and allows us to reach larger flip angles than is possible with previous methods. We then substitute ϕ_{new} for ϕ_{des} in Eq [1], and design a new set of pulses. The new pulses are added to the old pulses, and the process repeats with the summed pulses.

We verified our technique in simulation. Transmit sensitivity patterns were approximated by the receive patterns of an 8-channel receive coil array and a phantom. Peak B1+ magnitude of each pattern was scaled to 0.25 gauss/full RF magnitude. The ROI was defined by thresholding a body coil image of the phantom, and the desired pattern ϕ_{des} was defined as a rectangle of 180° flip angle, centered in the ROI (Fig. 1). The applied k-space trajectory was an undersampled spiral with excitation FOV of 7 and spatial resolution 20/32cm, corresponding to pulse length 2.4ms. The desired excitation pattern was specified on a 64x64 grid with 20cm FOV, and final excitation error was calculated on a 128x128 grid with 20cm FOV. Normalized RMS error (NRMSE) was calculated between the desired and excited flip angle patterns, and average tip angle was computed within the square. 15 Bloch/small-tip iterations and $\Delta=0.5$ were used.

RESULTS: Figure 2 contains meshplots of the flip angle patterns excited by small-tip designed pulses (2a) and additive-angle pulses (2b). The small-tip designed pulses represent those achieving the lowest excitation error with respect to β in Eq. 1 (6), and they produced an excitation pattern that is heavily distorted, with NRMSE=0.24, average flip angle of 151°, and standard deviation of 13°. In contrast, pulses designed using our technique produce undistorted excitation (2b) with NRMSE=0.08, average flip angle of 173°, and standard deviation of 1°. Computation time for our technique was 41s on a 3Ghz P4 PC in MATLAB, compared to 3s for small-tip pulse design.

CONCLUSION: In summary, the proposed approach provides rapid design of large-tip RF pulses for parallel excitation. It is an extension of previous one-dimensional pulse design methods that use Bloch equation simulations in an iterative manner to predict the distorted pattern excited by a small-tip designed pulse, and then add corrective small-tip designed pulses to that pulse to improve excitation accuracy. We have extended these methods to large-tip-angle pulse design in multi-dimensional parallel excitation, and introduced a modification that allows us to design accurate pulses for larger tip angles than was previously possible.

REFERENCES: [1] W Grissom et al. *14th ISMRM*, p3015, 2006. [2] J Ulloa et al. *14th ISMRM*, p3016, 2006. [3] JM Pauly et al. *JMR*, 82(3):571–587, 1989. [4] WE Kyriakos et al. *5th ISMRM*, p1990, 1997. [5] ET Lebsack et al. *IEEE Trans Biomed Eng*, 49:41–48, 2002. [6] JT Ngo et al. *MRM*, 5(3):217–237, 1987. [7] W Grissom et al. *MRM*, 56(3):620–9, 2006. [8] CY Yip et al. *MRM*, 56(5):1050–9, 2006. This work supported by NIH Grant R01 DA15410.

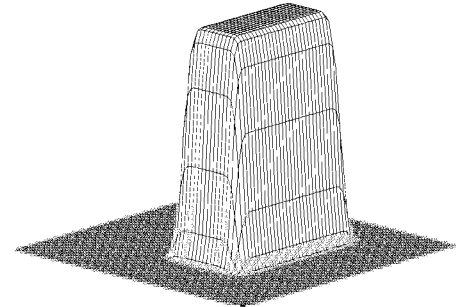
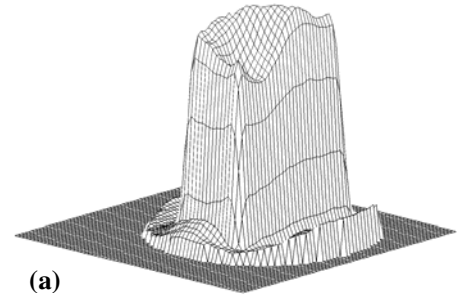
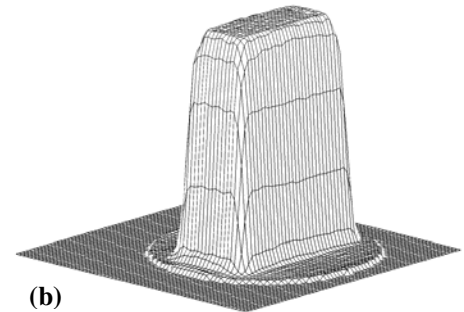

Figure 1: Desired flip angle pattern (5x10cm rectangle) for pulse design and error calculation.



(a)



(b)

Figure 2: Simulated flip angle patterns. **a:** Small-tip designed pulses, NRMSE=0.24, average flip angle=151°. **b:** Large-tip designed pulses, NRMSE=0.07, average flip angle=173°.